



# Welcome to the 2023 IMAC Judging Seminar

*Perfection is the singular standard against which all maneuvers are judged.*



# Course Outline

## Module 1 - Aresti Language

- Decoding Aresti
- Aresti Module Assessment

## Module 2 - General Principles

- Aircraft Specifications, Sound Limits, Official Flights, Time Limits
- General Principles Assessment

## Module 3 - Judging Principles

- Mental Attitude, Airspace Control, Flight Path, Attitude; Wind Correction, Grading Principles, Basic Components of Aerobatics
- Judging Principles Assessment

## Module 4 - Aresti Families 1 – 9

- Specific Judging Criteria
- Aresti Families Criteria Assessment

## Module 5 - Freestyle

## Module 6 - Review, Unknowns, Quality Judging

## Module 7 - 2019 Rules Changes Overview



# Decoding Aresti:

## The Language of Aerobatics

# Aresti Symbols



## Key Concepts

- Line Symbology
- Roll Symbology
- Snap Rolls
- Spins

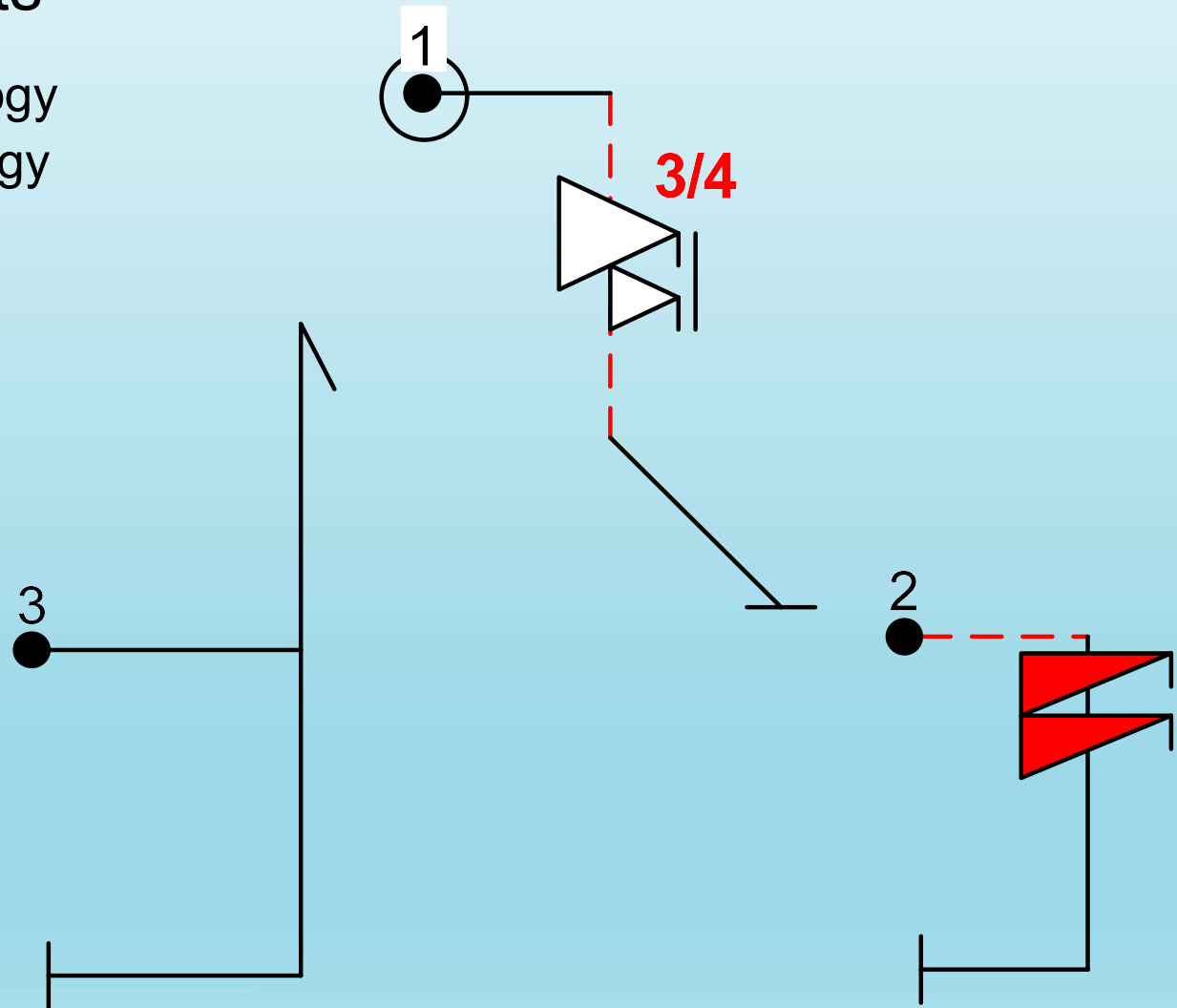

# Aresti Symbols



## Line Symbolology

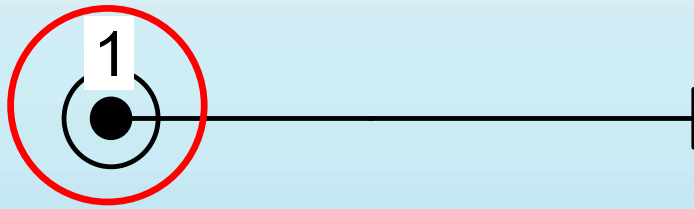

Sequence Start: First figure always has a partial circle around the start "blob"

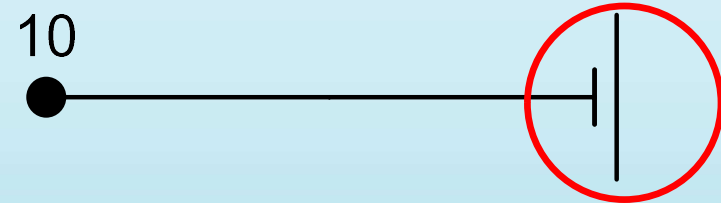
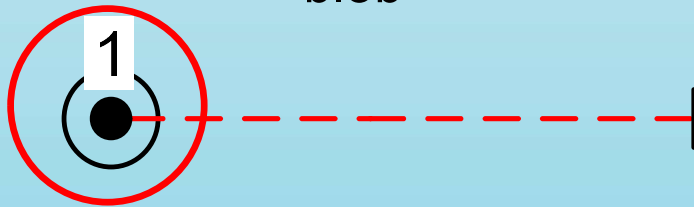

Sequence End: Last figure (usually 10) always indicated by 2<sup>nd</sup> "bar" following figure end.

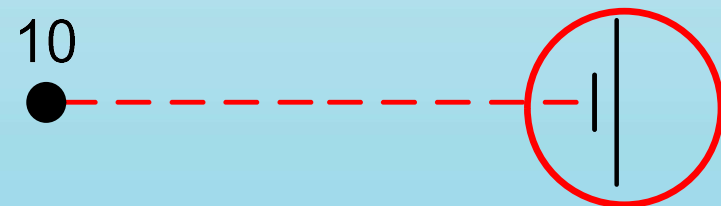

- Positive flight indicated with solid lines.
- Negative flight indicated with dashed lines.
  - Note: positive is not always upright; negative is not always inverted.

# Aresti Symbols



## Line Symbology

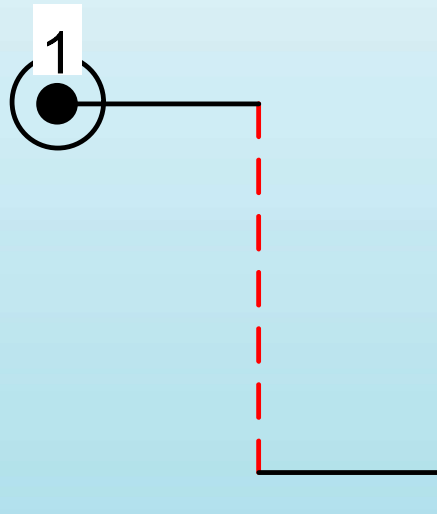

- Push to a down line.
- Negative G shown with dashed lines.
  - Vertical lines are indicated as solid or dashed based on the g-loading of the aircraft during the radius from horizontal to vertical flight.
- The second pull to an upright line is shown solid.

# Aresti Symbols



## Line Symbology

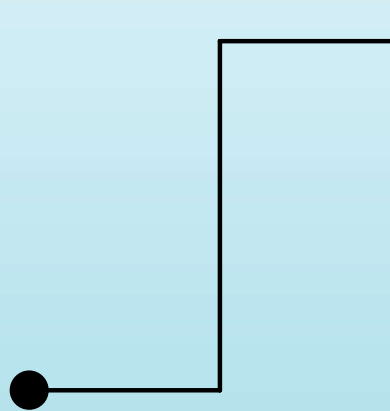

- Pull to up-line.
- Shown as a solid line.
  - Vertical lines are indicated as solid or dashed based on the g-loading of the aircraft during the radius from horizontal to vertical flight.
- Push to exit upright is a solid line.

# Aresti Symbols



## Roll Symbology

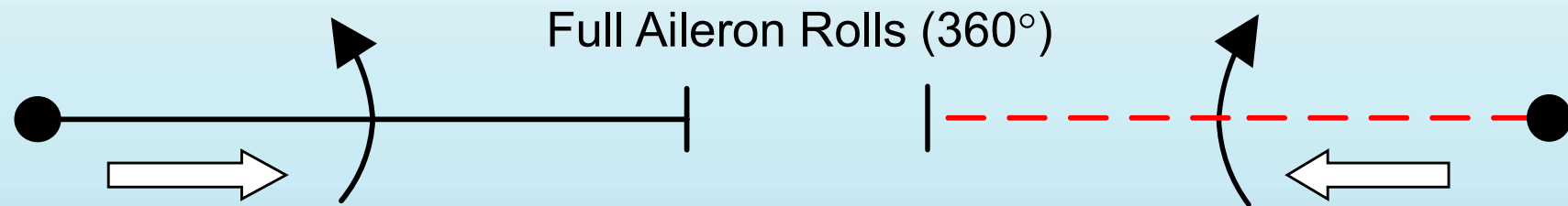

## Partial Aileron Rolls

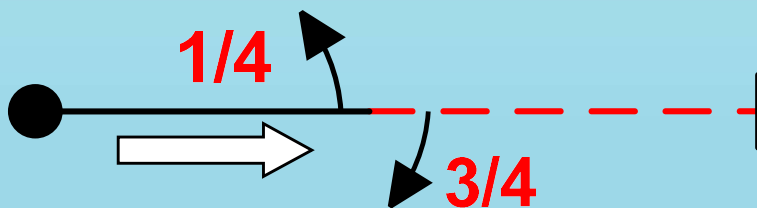

## Point / Hesitation Rolls

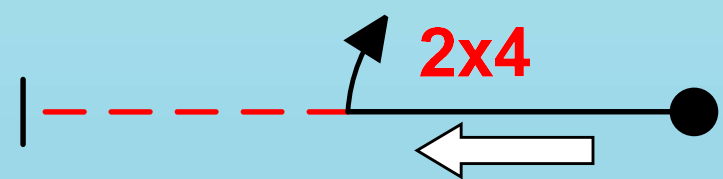

Note the different representations of partial rolls vs. point rolls.  
Direction of flight always into “cup” of roll indicator.



# Aresti Symbols



## Roll Symbolology

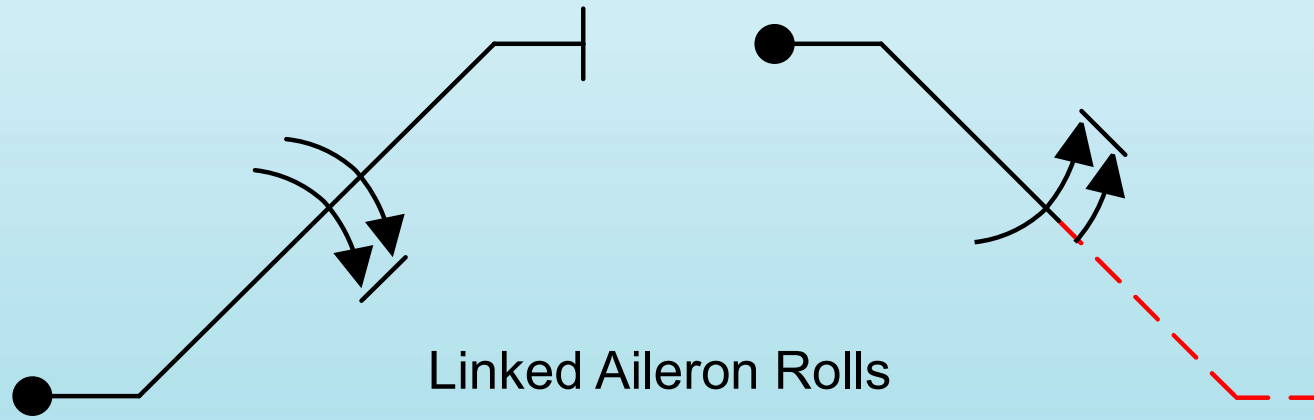

### Unlinked Opposite Aileron Rolls

Note: In unlinked combination rolls, any number indicators will appear on the arrow side of the roll elements it accompanies.

# Aresti Symbols



## Roll Symbolology

### Point / Hesitation Rolls

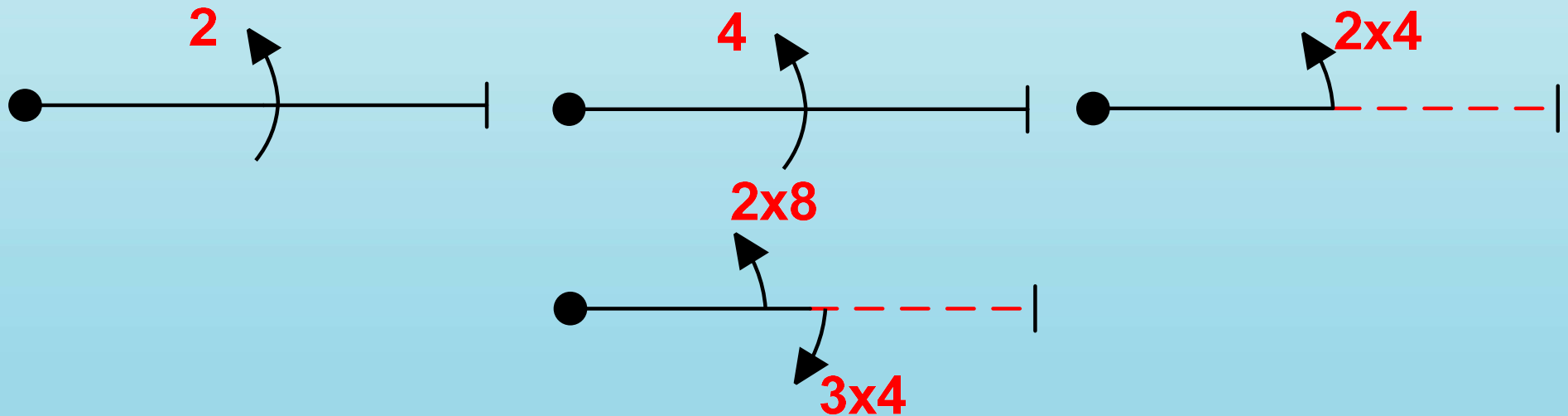

Note: In hesitation rolls, the number indicators will appear on the arrow side of the roll elements it accompanies.

# Aresti Symbols



## Roll Symbology

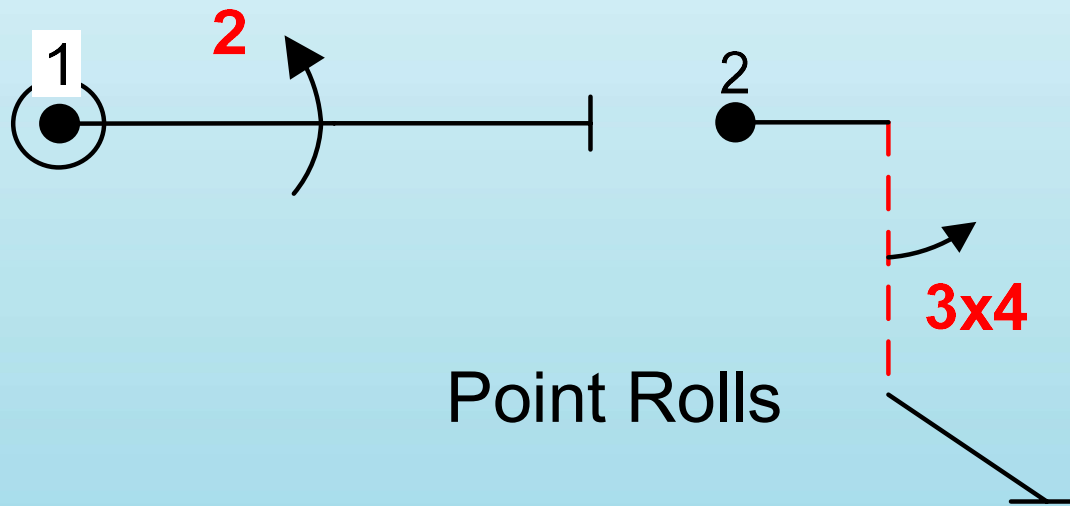

Point Rolls

- ❑ In a cross-box figure, flight along the 'Y' axis is shown with diagonal lines. The center figure can be flown directly into the next figure. Y axis is non-directional. Figures 2 & 3 could be flown in or out.

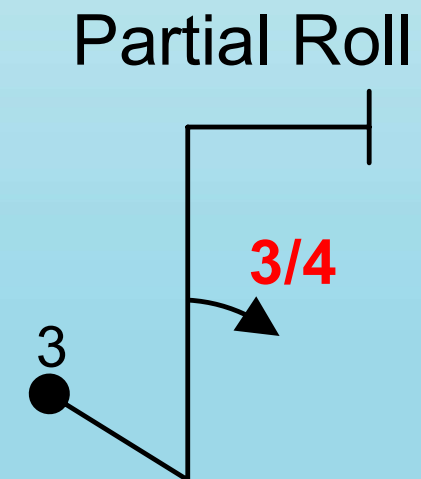

# Aresti Symbols



## Roll Symbology

## Partial Rolls

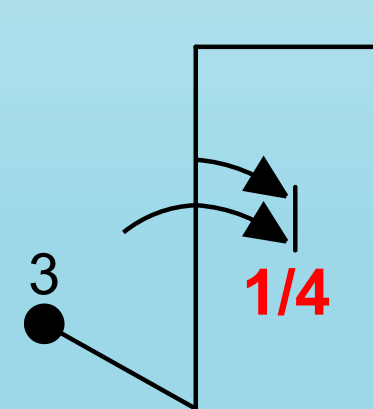
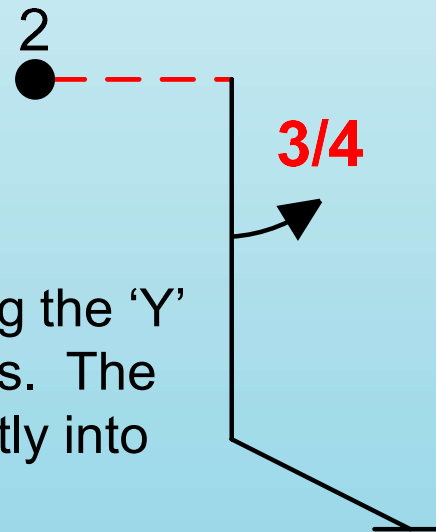
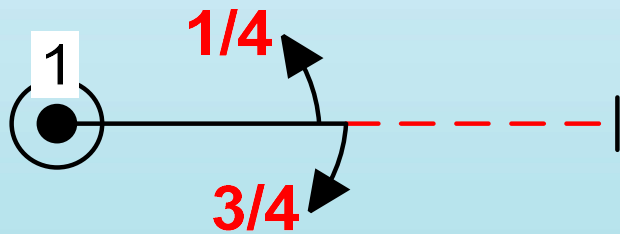

- ❑ In a cross-box figure, flight along the 'Y' axis is shown with diagonal lines. The center figure can be flown directly into the next figure. Y axis in non-directional. Figures 2 & 3 could be flown in or out.

# Aresti Symbols



## Roll Symbolology

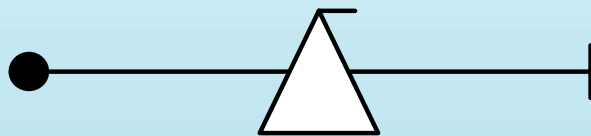

Positive Snap

## Snap / Flick Rolls

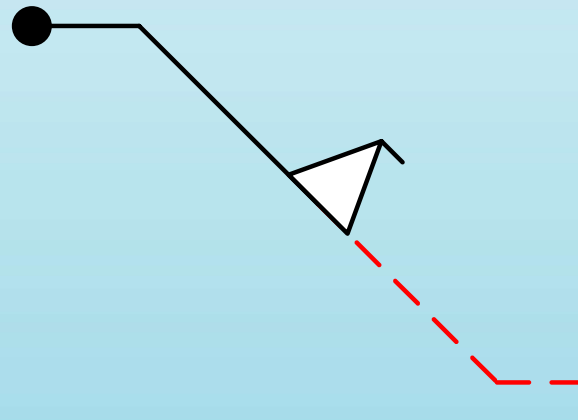

Half Positive Snap

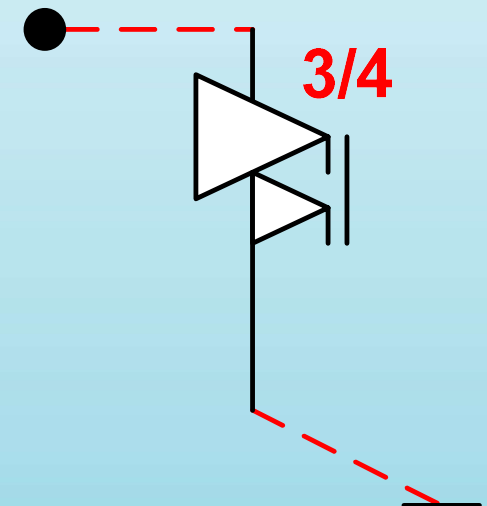

Linked Positive  
 $1\frac{3}{4}$  Snap

Note: "Flag" on the snap symbol is always with the direction of flight.

# Aresti Symbols



## Roll Symbology

## Snap / Flick Rolls



Negative Snap

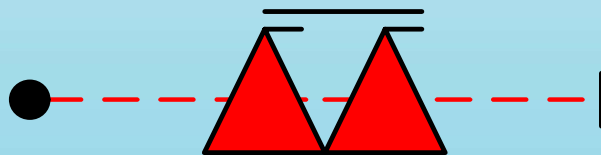

Two Linked Negative Snaps

Note: "Flag" on the snap symbol is always with the direction of flight.

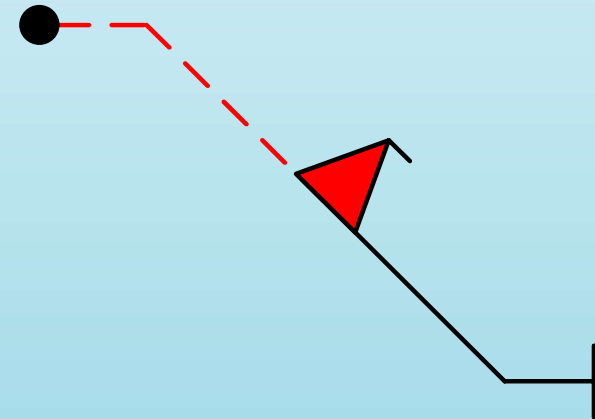

Half Negative Snap

# Aresti Symbols



## Roll Symbology

Snap / Flick Rolls + Rolls

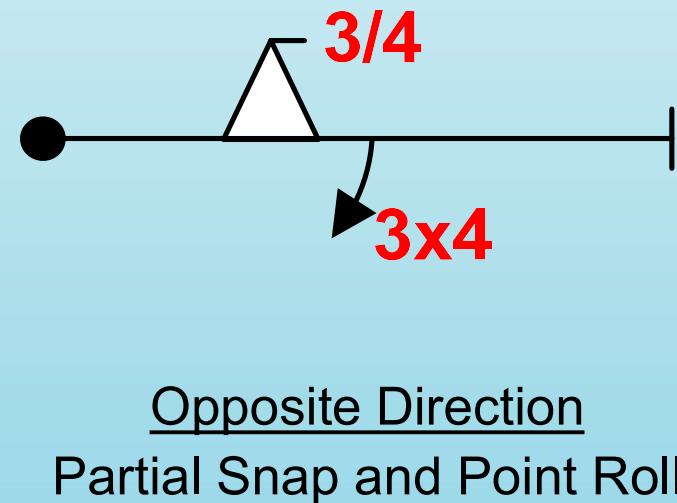
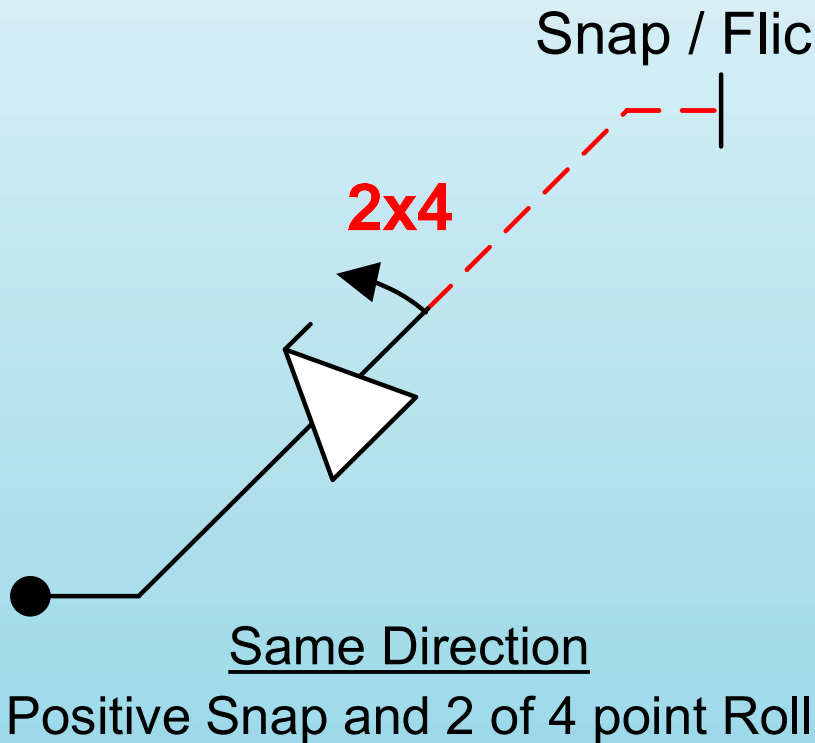

# Aresti Symbols



## Roll Symbolology

## Spins

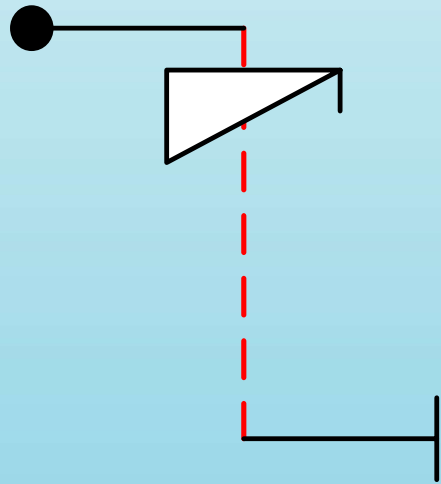

Positive Spin

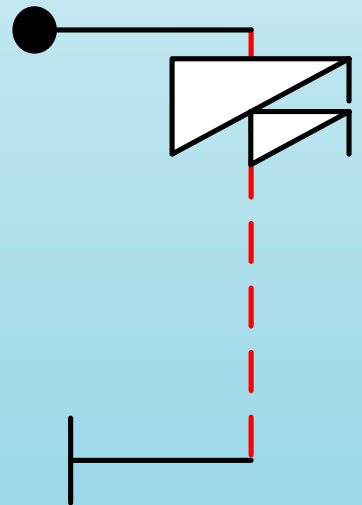

1½ Turn  
Positive Spin

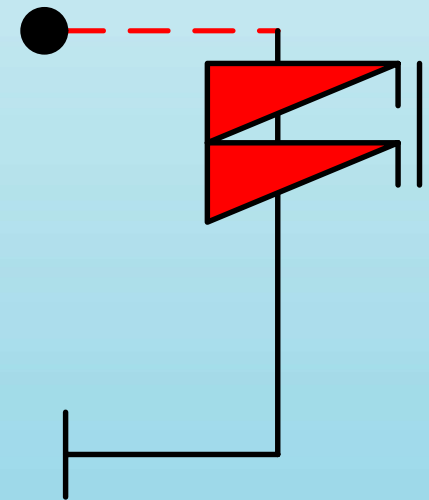

Two Turn  
Negative Spin



# Aresti Symbols



Roll Symbolology

Spins

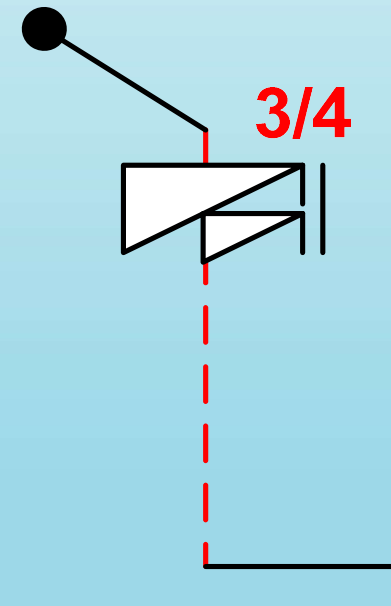
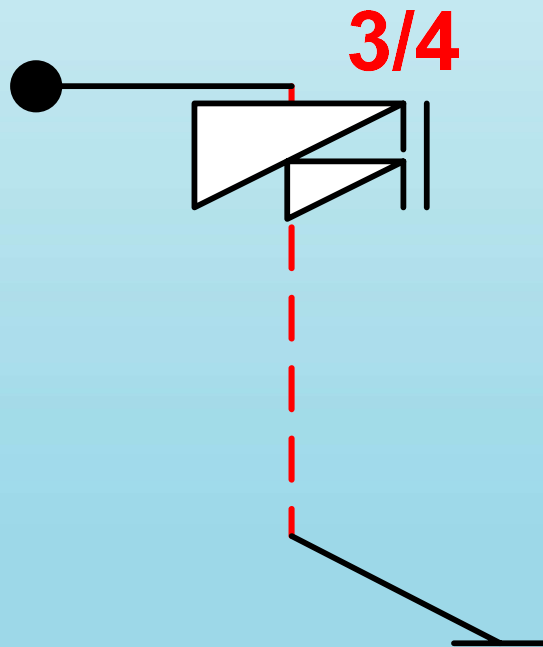

# Aresti Symbols



## Roll Symbolology

## Spins

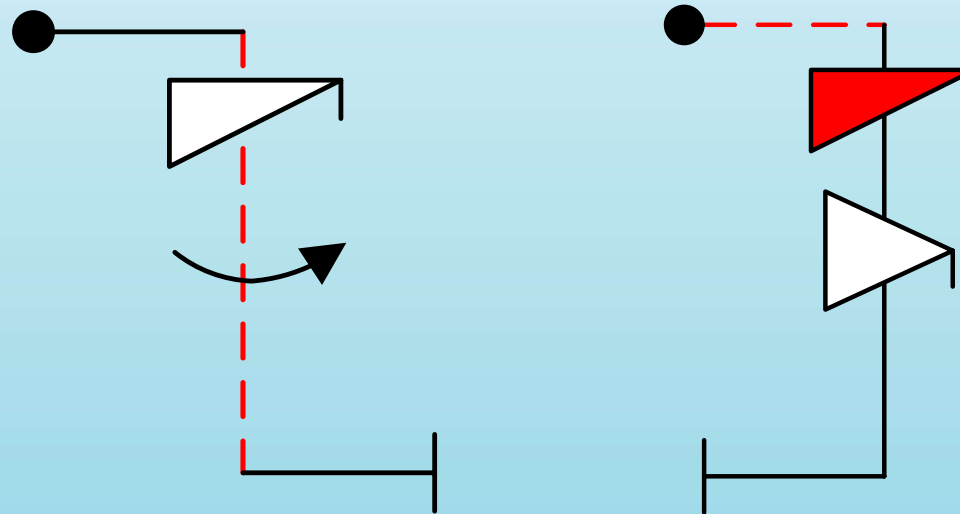

- ❑ Rolls and snap rolls may be combined with spins, but the spin element will always occur first.

# Aresti Symbols



- ❑ Aresti example
- ❑ Aresti catalog number list

Fig 1	2.4.1.1	6	6
Fig 2	5.2.1.1	17	17
Fig 3	1.2.3.1 9.1.2.2	12 6	18
Fig 4	1.1.1.1 9.1.3.4	2 8	10
Fig 5	8.5.6.1 9.1.4.2	10 4	14
Fig 6	8.4.1.1 9.1.5.2	13 4	17
Fig 7	7.4.1.1	10	10
Fig 8	8.5.9.1 9.1.5.2	12 4	16
Fig 9	7.2.2.1 9.1.3.2	6 4	10
Fig 10	1.1.6.3 9.11.1.6	10 3	13
<b>Total K = 131</b>			

**B** Contest: **2017 Official Basic Known**

Date: \_\_\_\_\_ Program: **BASIC** Known

**INTERNATIONAL MINIATURE AEROBATICS CLUB INC.**

wind direction

Fig 1	2.4.1.1	6	6
Fig 2	5.2.1.1	17	17
Fig 3	1.2.3.1 9.1.2.2	12 6	18
Fig 4	1.1.1.1 9.1.3.4	2 8	10
Fig 5	8.5.6.1 9.1.4.2	10 4	14
Fig 6	8.4.1.1 9.1.5.2	13 4	17
Fig 7	7.4.1.1	10	10
Fig 8	8.5.9.1 9.1.5.2	12 4	16
Fig 9	7.2.2.1 9.1.3.2	6 4	10
Fig 10	1.1.6.3 9.11.1.6	10 3	13
<b>Total K = 131</b>			

Created Using Aresti 6™ software - ACC@aerobats.com



# General Principles

Aircraft Specifications 4.3

SA sound Limits 5.1

Official Flights 10.1 – 10.3

Time Limits 13.1 – 13.5

# General Principles



## Aircraft Specifications

### 4.3

#### **Aircraft Specifications**

- Airborne devices that place the aircraft under less than full control of the pilot are prohibited.
- Such devices include but are not limited to: gyros, automatic pilots, electronic stabilization systems, and timing devices.
- These devices are not permitted on board the aircraft – having them on board but inactive is **not** acceptable.
- Any pilot found using such a device will be disqualified from the event.
- Non-airborne functions (transmitter based) are permissible.

# General Principles



## Sound Score

### 5.1

#### **In-Flight Judging Criteria, Known and Unknown Sequences.**

- ❑ Judges will evaluate each individual sequence flown in its entirety for overall sound presentation. Each judged Known and Unknown sequence shall have one “figure” added to the end of the score sheet after individually judged maneuvers. This figure shall be known as the Sound Score.
- ❑ The sound presentation will be scored on a scale of 10 to 0 with 10 denoting “Very Quiet,” and 0 denoting “Very noisy.” Whole points will be used for scoring. This sound score will then be multiplied by the K value for the individual class and included in the total flight score for the sequence. Note that each judge’s score is independent of the other(s) and no conferencing on the sound score is required.

# General Principles



## Sound Score

### 5.1

- ❑ If a pilot receives a sound score of three (3) or less for the same sequence from two or more judges, the pilot will be notified of the problem and will be requested by the Contest Director to adjust or modify the aircraft in order to reduce the sound level prior to the next round. If that pilot, after notification, again receives a sound score of three (3) or less for the same sequence from two or more judges, that pilot will be disqualified from further competition at that contest.

# General Principles



## Official flights

10.1 – 10.3.2

- ❑ Official Flights for Known Program: 10.1.1
  - Pilots are allocated one “attempt” per sequence to complete the sequence.
  - An attempt begins with the mandatory vocal declaration by pilot or caller, i.e., “In the box.”
  - Omission of the vocal declaration zeros the sequence for which no vocal signal was made.
  - Once the vocal signal is made, judging begins the moment the aircraft departs wings-level, horizontal flight and enters the first figure.



# General Principles



## Official flights

10.1 – 10.3.2

- ❑ Official Flights for Known Program: 10.1.1 – 10.1.3
  - If a known sequence can not be completed due mechanical problems the contestant will receive zeros for each figure remaining in the sequence.
  - If the second sequence is yet to be flown and the aircraft can be made airworthy, the contestant may attempt the second sequence.
  - If the aircraft cannot be made airworthy, the contestant may attempt the second sequence with an alternate IMAC legal airplane. In such cases, the contestant will be placed last in the flight order at no penalty.
  - Contestants are to be able to complete two (2) sequences without landing to refuel (**see rule 11**). If two (2) sequences can not be completed, any un-scored maneuvers will receive a zero (unless 10.1.2 applies).

# General Principles



## Official flights

10.1 – 10.3.2

- ❑ Official Flights for Unknown Program: 10.2.1 – 10.2.2
  - Defined as one sequence.
  - Pilots are allocated one “attempt” to complete the sequence.
  - An attempt begins with the mandatory vocal declaration by pilot or caller, i.e., “In the box.”
  - Omission of the vocal declaration zeros the sequence for which no vocal signal was made.
  - Once the vocal signal is made, judging begins the moment the aircraft departs wings-level, horizontal flight and enters the first figure.

# General Principles



## Official flights

10.1 – 10.3.2

- ❑ Official Flights for Unknown Program: 10.2.1 – 10.2.2
  - If an unknown sequence can not be completed due to mechanical problems the contestant will receive zeros for each remaining figure of the sequence.

# General Principles



## Official flights

10.1 – 10.3.2

- ❑ Resumption of Scored Flight: 10.3.1 – 10.3.2
  - Any sequence interruption (known or unknown) requires that the pilot resume with the figure prior to the interruption (last scored figure). The pilot must re-establish a horizontal line, make a vocal declaration, and re-fly the last scored figure. Judging resumes after completion of said prior figure.
  - Mid-air collision is considered beyond the control of the pilot.
    - If still airborne, each involved aircraft must land and pass a safety inspection by the CD prior to resuming.
    - Pilots may resume the sequence with an alternate aircraft.
    - Contestant must declare their intent to complete the round or not. If continuing, the pilot will be placed last in the flight order and resume the sequence with the last scored figure prior to the interruption.

# General Principles



## Time Limits

13.1 – 13.5

### □ Time Limits: 13.1 – 13.4

- Pilots have two (2) minutes to start engine and become airborne. Failure to achieve engine start moves the pilot to the end of the flight order. A second failed start incurs a zero for the round.
- Once airborne, pilots have one (1) minute to enter the airspace.
- Upon exiting the airspace / sequence, pilots have 2 minutes for landing unless otherwise instructed.

Note: Exceptions to Time Limits may be in place at the CD's discretion in the course of managing the contest and airspace.

# General Principles



## Time Limits

13.1 – 13.5

- ❑ Time Limits: 13.5 – Legal Turn Around Figures
- ❑ The following are the ONLY allowable maneuvers prior to entering the Aerobatic Airspace, between sequences, and prior to landing:
  - Turns.
  - Half Cubans or Reverse Half Cubans with only a single  $\frac{1}{2}$  roll on the 45 degree line. Note: The  $\frac{1}{2}$  roll is optional based on the aircraft orientation required to initiate the aerobatic sequence. If a pilot elects to omit the half roll and exit the turn-around figure inverted, he or she is committed to an attempt and must initiate the sequence.
  - Single  $\frac{1}{2}$  roll to inverted immediately prior to an attempt when the first figure requires an inverted entry.
  - Single  $\frac{1}{2}$  roll to upright following an inverted exit from the last maneuver.

# General Principles



## Time Limits

13.1 – 13.5

- ❑ Time Limits: 13.5 – Legal Turn Around Figures – continued.
  - Half Loops:
    - 1) Half inside loop with only a single  $\frac{1}{2}$  roll on entry or exit. Note: The  $\frac{1}{2}$  roll is optional based on the aircraft orientation required to initiate or exit the aerobatic sequence [New 2019].
    - 2) Half outside loop to upright for sequences that end in inverted flight [New 2019].
  - Vertical lines (up or down) are **not** legal turn-around figures [Changed 2019].

# General Principles



## Time Limits

13.1 – 13.5

- ❑ Time Limits: 13.5 – Legal Turn-Around Figures
  - Turn-Around figures are not to be performed at low altitude or directly in front of the judges.
  - An illegal maneuver performed before entering a sequence will result in zeroing the following sequence. An illegal maneuver prior to landing will result in zeroing the preceding sequence.
  - Exceptions to turn-around figures may be made at the CD's discretion in the course of safely managing the contest and airspace.



# General Principles



## Time Limits

13.1 – 13.5

❑ Time Limits: 13.5 – Legal Turn Around Figures

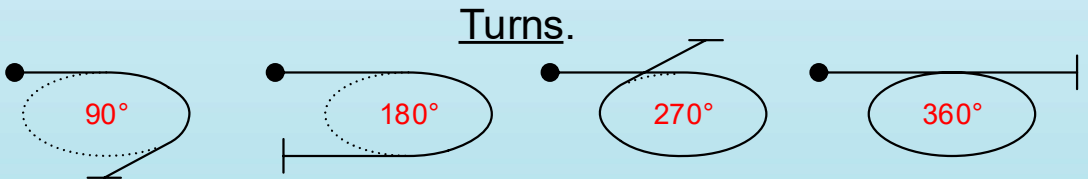

Reverse 1/2 Cuban or 1/2 Cuban  
Though displayed, the 1/2 roll on the 45 degree lines is optional; may be omitted when inverted entry is required.

1/2 Loop up or down.  
A single 1/2 roll on either entry or exit is permitted on either half loops up or down

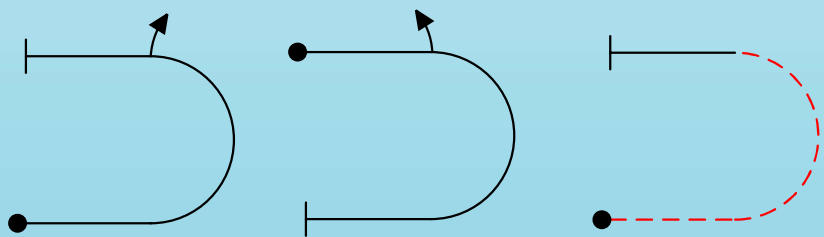
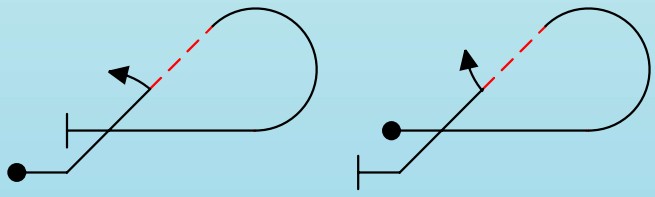

Note: 1/2 Outside loop up is permitted when sequences end inverted.

Single 1/2 Roll  
A single 1/2 roll to inverted prior to the sequence start for inverted entry, or a single 1/2 roll to upright after sequences that finish inverted.





# Judging Principles

Mental Attitude 1.1 – 1.1.5

Airspace Control 4.3

Flight Path, Attitude; Wind Correction 5.1 – 5.3

Grading Principles 6.1 – 6.3

Basic Components of Aerobatics 7.1 – 7.2.2

# Judging Principles



## Mental Attitude

1.1.1 – 1.1.5

- ❑ Mental Attitude can be divided into six sub-categories:
  - Bias
  - Technical Knowledge
  - Rules Adherence
  - Self Confidence
  - Independence
  - Complex Figure Bias

# Judging Principles



## Mental Attitude

1.1.1 – 1.1.5

### ❑ Bias - 1.1.1

- Can be either conscious or subconscious.
- Conscious bias - deliberately awarding an improper score = *cheating*.
- Subconscious bias – Unintentionally awarding points based on recognition, also known as the “halo-factor” or unintentionally assessing downgrades due to familiarity. Other factors contributing to subconscious bias:
  - Style differences
  - Aircraft size or type.
  - Equipment preferences

# Judging Principles



## Mental Attitude

1.1.1 – 1.1.5

- ❑ Technical knowledge 1.1.5
  - Apply a consistent, organized method of downgrading.
  - All maneuvers begin at a score of 10 and are downgraded per the criteria as the maneuver progresses.
  - Issue scores based on specific faults within the maneuver rather than overall impression of the maneuver.
  - Strive for a high degree of consistency and accuracy. Should maintain that standard throughout the contest.

# Judging Principles



## Mental Attitude

1.1.1 – 1.1.5

### Adherence to the Rules – 1.1.4

- Good judges understand that a fair contest results from all flights being judged by a standard and unchanging set of rules.
- Anyone unwilling to judge all pilots by the existing rules should disqualify him or herself.

### Self Confidence – 1.1.2

- Confident judges record scores based on their knowledge of the rules, independent of personalities and ego.
- Confident judges know, understand; apply the criteria.
- Confident judges are comfortable recording a wide range of scores regardless of the pilot (World Champion or local pilot).

# Judging Principles



## Mental Attitude

1.1.1 – 1.1.5

### Sense of Independence – 1.1.3

- Judging is an *independent practice*: Do not influence or allow yourself to be influenced by others on the flight-line – other judges, scribes, callers, etc.
- Communication with scribes should be conducted such that others cannot overhear.

# Judging Principles



## Mental Attitude

1.1.1 – 1.1.5

## Complex Figures Judging / Bias

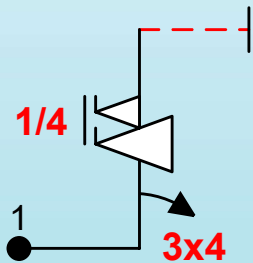

- 1<sup>st</sup> pt (-10°) + 2<sup>nd</sup> pt (+5°) = -1.5
- Snap ovr rot (15°) = -1.5
- Grade = 10 - 3.0 = 7.0

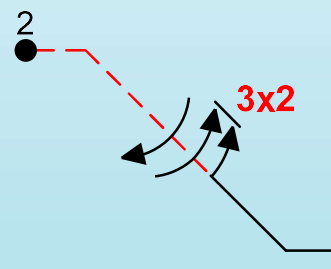

- 45 before (-10°) = -1.0
- Varied roll rate twice = -2.0
- Grade = 10 - 3.0 = 7.0

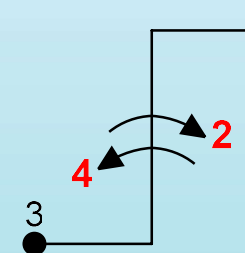

- 4x4, 2 pts (+5° @) = -1.0
- 2x2 ovr last point 10° = -1.0
- Exit off hdg (10°) = -1.0
- Grade = 10 - 3.0 = 7.0

Carefully examine each individual figure and its appropriate downgrades.



# Judging Principles



## Mental Attitude

1.1.1 – 1.1.5

## Complex Figures Judging / Bias

Now combine those three figures into one complex figure:

If the complex figure is flown with the same errors as the individual figures, what is the score?

**1.0!**

Yet, it is common to see scores of 6 – 8 due to subconscious bias against giving low scores to highly experienced pilots.

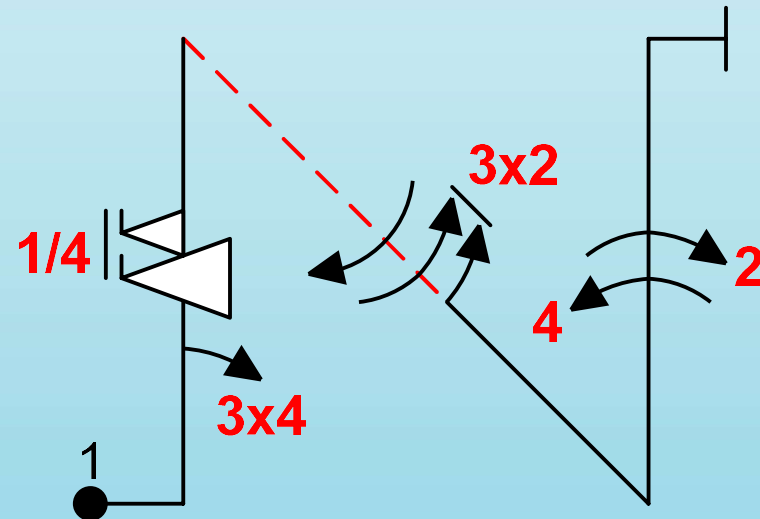

Low scores do not necessarily indicate poor flying!

This is a demanding sport flown against very high standards - **perfection**.

Judges must be confident; record the mark earned regardless of pilot's history, flying style, equipment choices, or perceived difficulty of the figure.

# Judging Principles



## Air Space Control

### 4.3

- ❑ The following criteria will be used for assessing the pilot's performance in maintaining control and awareness of the aerobatic airspace, and placing figures in the airspace in a manner that allow the figures to be optimally judged.
- ❑ The HIGHEST standard for Airspace control:
  - The pilot that exhibits a significant ability to control the location of the aircraft inside the Airspace relative to the Judges, employs a tight footprint, and locates the aircraft such that it can be optimally judged at all times should receive a TEN (10).

# Judging Principles



## Air Space Control

### 4.3

- ❑ The LOWEST standard for Airspace control:  
The pilot that exhibits a poor ability to control the location of the aircraft inside the Airspace relative to the Judges, displays an excessively large footprint and has the aircraft consistently so far away as to be difficult to properly judge.
  - This pilot exhibits a very poor Airspace control and should receive a zero (0).
  - Pilots exhibiting Airspace control within the range of these two standards will be graded with a range of possible scores from ten (10) to zero (0) in whole point increments.
- ❑ K factors for the Airspace Control Scores are:  
Basic: 3, Sportsman: 6, Intermediate: 9, Advanced: 12, Unlimited: 15.

# Judging Principles



## Flight Path, Aircraft Attitude and Wind Correction

5.1 – 5.3

- ❑ Scale Aerobatics requires all maneuvers within the sequence to be wind corrected – rule 5.3.
- ❑ Judges must evaluate every maneuver on the aircraft's flight path rather than attitude, but at the same time downgrade for variations in attitude not directly related to maintaining the correct flight path.
- ❑ Maneuvers where the aircraft is in a stalled or near-stalled condition are exceptions to this rule:
  - Hammerhead
  - Tail Slide
  - Spin
  - Snap roll

# Judging Principles



## Flight Path

### 5.1

- ❑ Picture the aircraft condensed to a dot – judge the path or track this dot draws in the sky. This is the flight-path or track of the aircraft's center of gravity.
- ❑ Judging flight path consists of comparing the observed path with fixed references such as the horizon or the airspace's X and Y axes.
- ❑ Flight path must be Horizontal, Vertical, or on a 45° line.
  - Exception: Turns - horizontal path is constantly changing but vertical path remains unchanged.

# Judging Principles



## Attitude

### 5.2

- ❑ Refers to the specific position of the aircraft in yaw, pitch, and roll axis.
- ❑ In no-wind conditions, attitude and flight path will typically be the same.
- ❑ In windy conditions, attitude may vary in the pitch and yaw axes to maintain the proper flight path.
- ❑ Speed changes also effect attitude in relation to flight path.

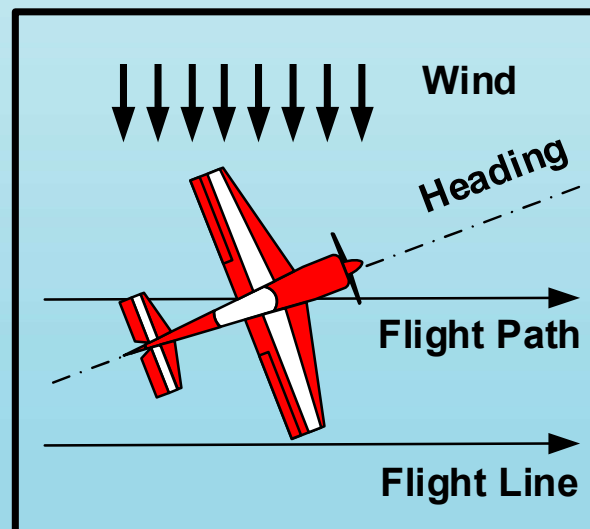

*Cross winds will force the aircraft to 'crab' or change its attitude in order to maintain a flight path parallel to the flight line.*

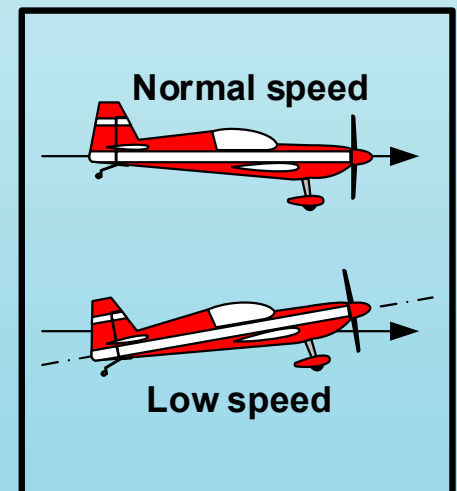

*At normal speed, the attitude is similar to the flight path. When the speed is reduced, the attitude may change to maintain a constant flight path.*

# Judging Principles



## Wind Correction

### 5.3

- Judges must ignore pitch and yaw attitude changes required to maintain proper flight path. Changes not related to wind correction are deducted at  $\frac{1}{2}$  pts per 5 degrees deviation.
- Aircraft must maintain a wings-level attitude while wind-correcting in the pitch and yaw axis.
- Wind correction is to be employed throughout the airspace.
- Drift observed on any line (horizontal, vertical, or 45 degrees) is downgraded at  $\frac{1}{2}$  pt per 5 degrees deviation.



Wind Corrected Loop

Click anywhere on screen to start video



# Judging Principles



## Wind Correction

### 5.3

- All maneuvers are to be flown in their perfect geometric shapes regardless of wind conditions.
- Loops and partial loops must be round.
- Vertical lines must track perpendicular to the horizon.
- Horizontal lines must track parallel to the X or Y axis.
- 45 degree lines must track on a true 45.

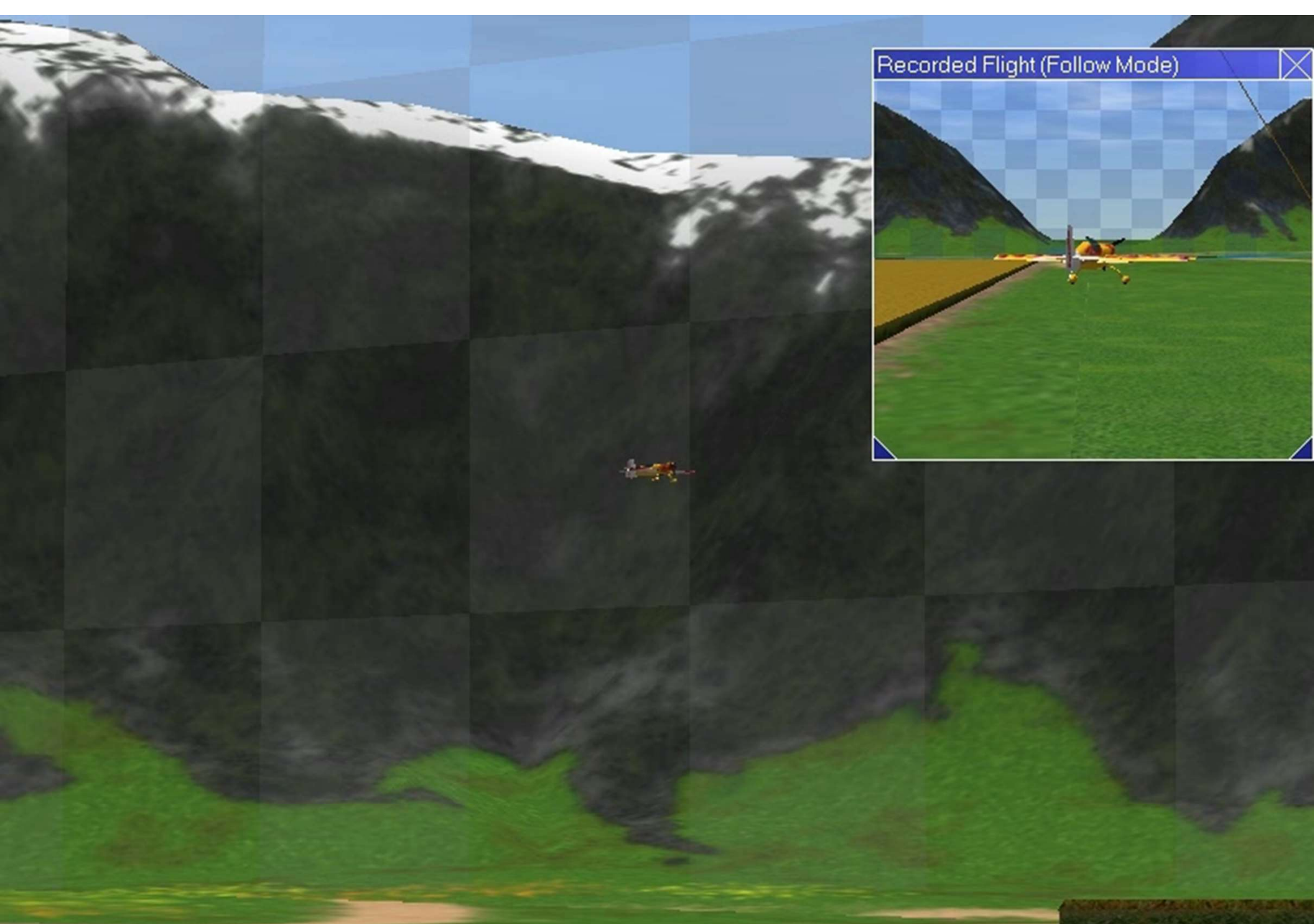

## Wind Corrected 2pt Roll

Click anywhere on screen to start video

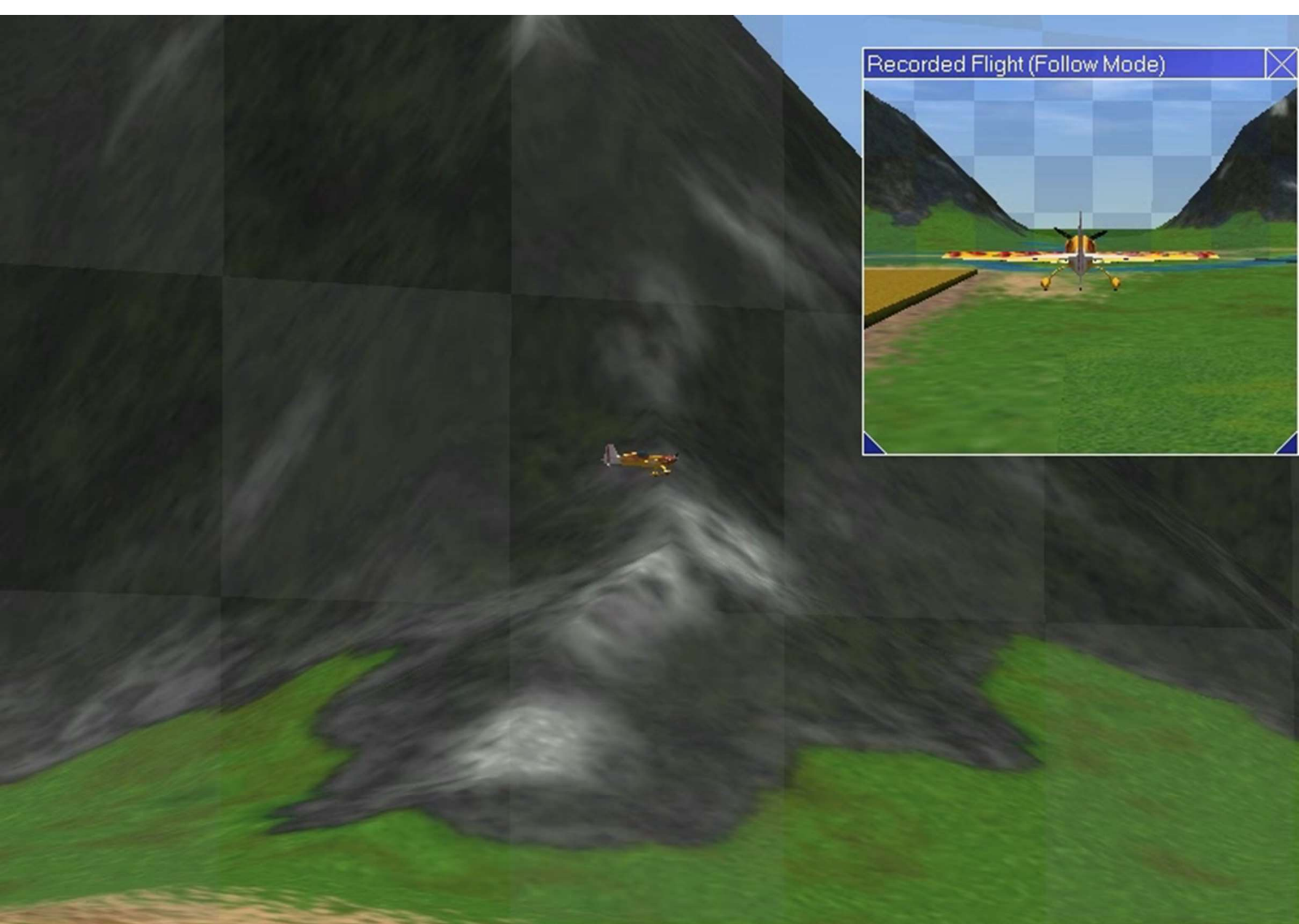

# Wind Corrected Humpty Bump

Click anywhere on screen to start video

# Judging Principles



## Wind Correction

5.3

Vertical lines must be wind corrected.

No Wind -  
Path and  
Attitude  
are both  
Vertical

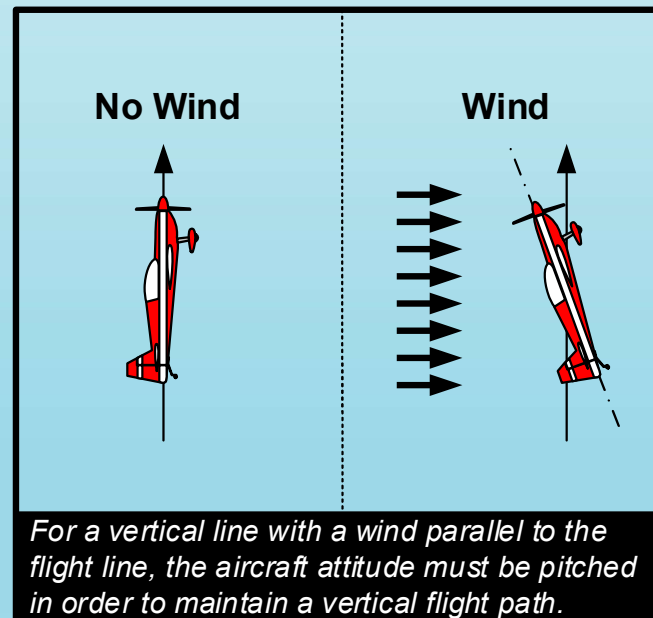

Wind - Path is  
Vertical and  
Attitude is  
wind  
corrected.

# Judging Principles



## Wind Correction

5.3

45° lines must be wind corrected

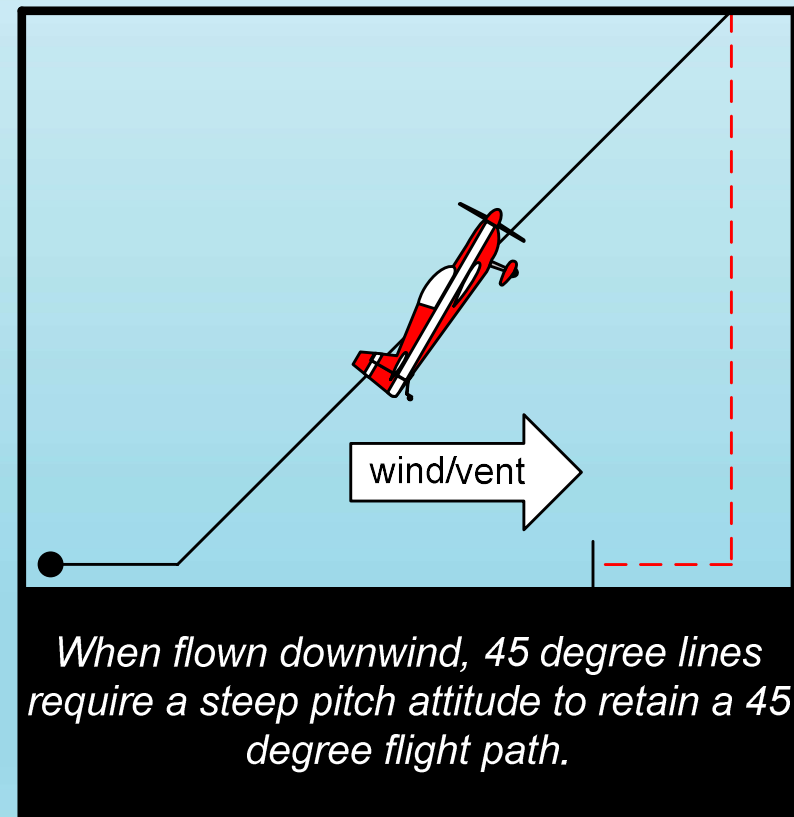
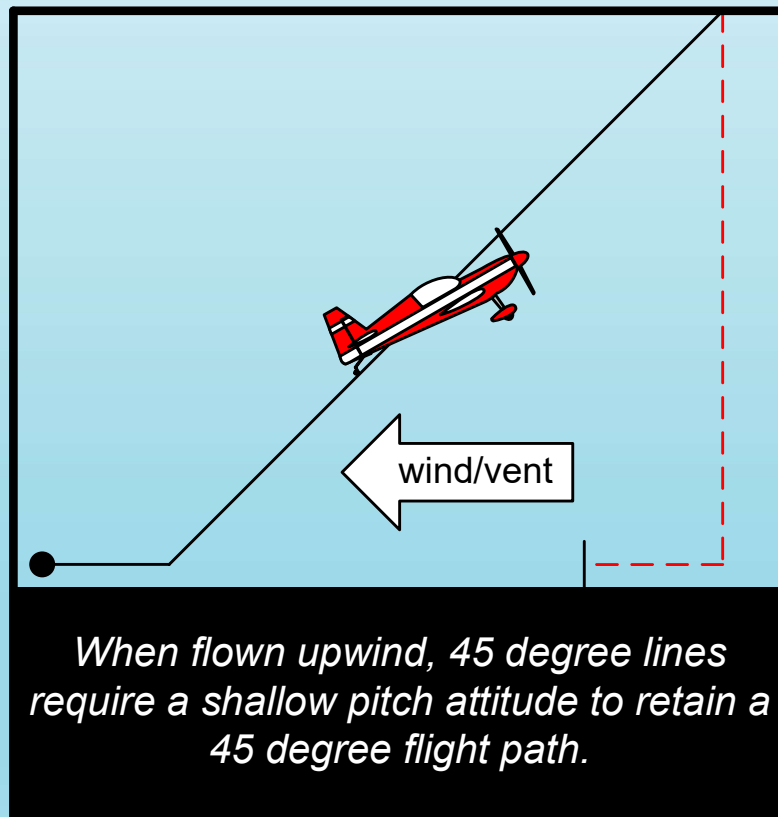

# Judging Principles



## Wind Correction

5.3

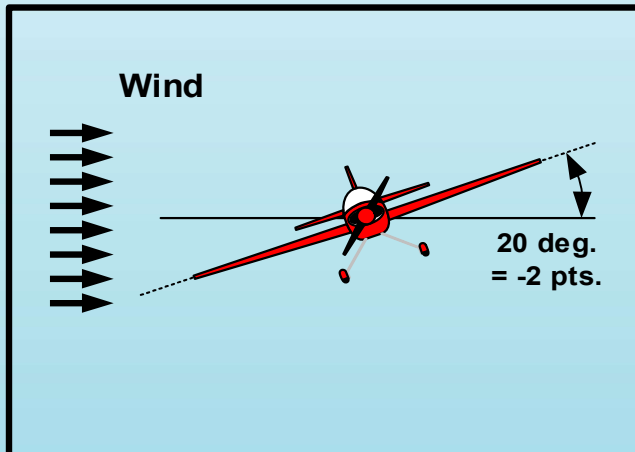

*In a cross wind situation, only the yaw axis is to be used for wind correction. Any change in the roll axis should not be considered wind correction and must be downgraded*

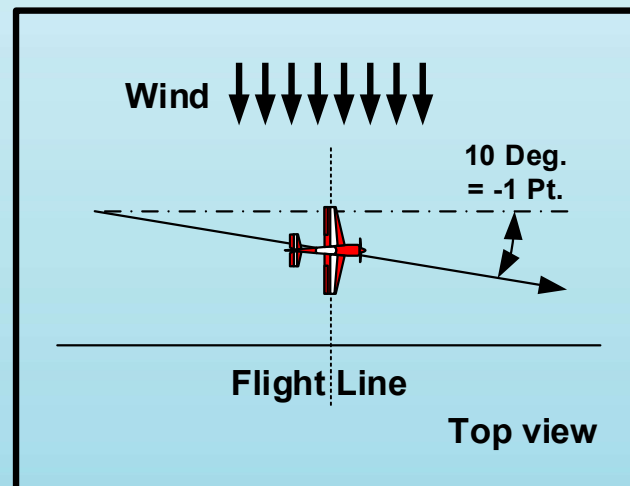

*Drift on horizontal line, due to cross wind should be penalized by ½ pt. per 5° deviation.*

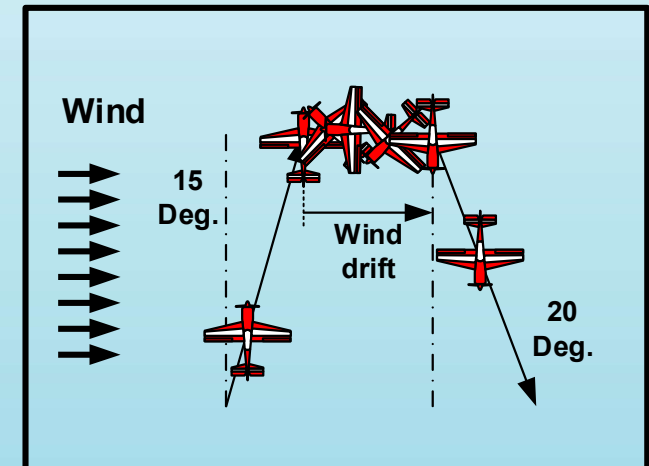

*In the case of a cross wind hammerhead, the above maneuver should not receive more than a 6.5 score (no downgrade for wind drift while stalled).*

# Judging Principles



## Wind Correction

### 5.3

- ❑ Portions of four (4) specific maneuvers are not wind corrected due to the aircraft being in a stalled condition. Wind drift is disregarded ONLY during the stalled portion:
  - Stall Turn (Hammerhead)
  - Tail slide
  - Spin
  - Snap Roll (Flick Roll)

# Judging Principles



## 6. Grading of Figures:

***Perfection is the standard against which all figures are judged.***

- ❑ Ten (10) to zero (0) in increments of one-half (0.5) point. Deductions are graded at .5 points per 5 degrees angular error and roll error. A grade of ten (10) represents a perfect figure in which the judge saw no deviations from prescribed criteria.
  - Judging Criteria Include:
    - Track (wind corrected true horizontal, vertical and 45° lines, and all loops and part loops.)
    - Loops and part loops – radii criteria.
    - Roll elements
- ❑ Remember, it is the judge's job to find fault: Be a nitpicker.
- ❑ Judges are expected to grade only against one standard: **Perfection.**
- ❑ Two (2) judges should be used to judge each sequence.



# Judging Principles



## 6. Grading of Figures:

### ❑ Radii Criteria - Loops and Part Loops:

- All radii, regardless of the figure's Aresti family, must be smooth, constant, and uninterrupted – visible variations in radius are downgraded at 1 (one) point per occurrence.
- Flat spots in a radius are downgraded at 1 (one) point per occurrence.
- Where radii of part loops must match, each mismatch is downgraded at 1 (one) point per occurrence.
- Where complete loops or part loops must match, each mismatch is downgraded at 1 (one) per occurrence.

# Judging Principles



**$5^\circ = 1/2$  point**  
**So, what does  $5^\circ$  look like?**



**Remember that 1 minute on a clock =  $6^\circ$ .**  
**Most judges actually underestimate angular error.**

# Judging Principles



## 6. Grading Principles:

### 6.1 General Principles

- The geometry of the figures presented (including the shape, radii, angles, flight path, direction of flight, heading and bank angle) must comply with the prescribed criteria.
- The precision of the performance compared to the criteria as explained later in this guide.
- The distinctly recognizable start and finish of each figure with a horizontal line.
- The figure must be the one depicted on the flimsy (Form B or C) appropriate to the direction of the flight chosen by the pilot

# Judging Principles



## 6. Grading Principles:

### 6.1 General Principles cont.

- The grading criteria of each component will apply in a combination figure so that one overall grade for the figure will result.
- The length of the lines and the size of the radii caused by the flying characteristics of an aircraft are not to be taken into account in the grading.
- Negative figures are graded by the same criteria as positive figures.
- Speed of aircraft is not a criterion.

# Judging Principles



## 6. Grading Principles:

### 6.2 Beginning & end of a figure

- The first figure, and judging of a sequence begins the moment the aircraft departs from its wings-level, horizontal flight path.
- A figure is complete at the moment the aircraft returns to a wings-level, horizontal flight path of one fuselage length.
- The only exception to this are the exit lines in the “Aresti Aerobatic Catalogue (Condensed)”, Families 7.4.3 and 7.4.4 (Square Loops) and 7.4.6 (Octagon Loops).
- Once a horizontal flight path of one fuselage length is established at the end of a figure, the beginning of the next figure is deemed to have occurred.

# Judging Principles



## 6. Grading Principles:

### 6.3 Zeros

- Omitting a figure in the program.
- Flying a figure that deviates from the Aresti drawing held by the judges for scoring purposes.
- Adding a figure to a program will zero the next following correct figure **except** when the added figure is a Corrective Maneuver (c.1) due to the previous maneuver not being completed as per the program.
- A Corrective Maneuver can only be a turn of 270 degrees or less, and/or a roll of 180 degrees or less. In this case, a “Break Penalty” will be assessed against the competitor’s raw score prior to normalizing (Fig 9).

# Judging Principles



## 6. Grading Principles: 6.3 Zeros continued

See rules regarding Corrective Maneuvers, Sequence Interruptions, and application of Break Penalty.

The diagram is divided into two parts by a vertical dashed line. The left part, labeled 'Correct maneuver', shows a model airplane performing a continuous sequence of maneuvers: a vertical climb, a loop, a half roll, and a landing. The right part, labeled 'Sequence Interruption', shows the same sequence but with an interruption. An arrow points to a gap in the sequence where an element was omitted, with the text 'Omitted element = zero for #1'. Another arrow points to a corrective maneuver (a half roll) performed after the end of the first maneuver, with the text 'Corrective maneuver = a Break penalty added to #1 #2 is now scored'. Below the diagram, a black box contains the following text:

*If part of the maneuver is either omitted or added, all of maneuver #1 must be zeroed and an Sequence Interruption has occurred. The half roll performed after the end of maneuver #1 (corrective maneuver) will cause a break penalty added to #1. Maneuver #2 will be judged.*

# Judging Principles



## 6. Grading Principles:

### 6.3 Zeros continued

- ❑ Note: Corrective actions that exceed 270 degrees of turn and or 180 degrees of roll constitute a Break in Sequence.
- ❑ Break in Sequence: Characterized by a total departure from the sequence to be flown that exceeds the limits of a Corrective Maneuver (Fig 10).
- ❑ A Break in Sequence zeros the maneuver in progress at the time the break occurs (Refer to 6.2 – Beginning and end of figures), and incurs a Break Penalty.



# Judging Principles



## 6. Grading Principles: 6.3 Zeros continued

See rules regarding Break in Sequence and application of Break Penalty.

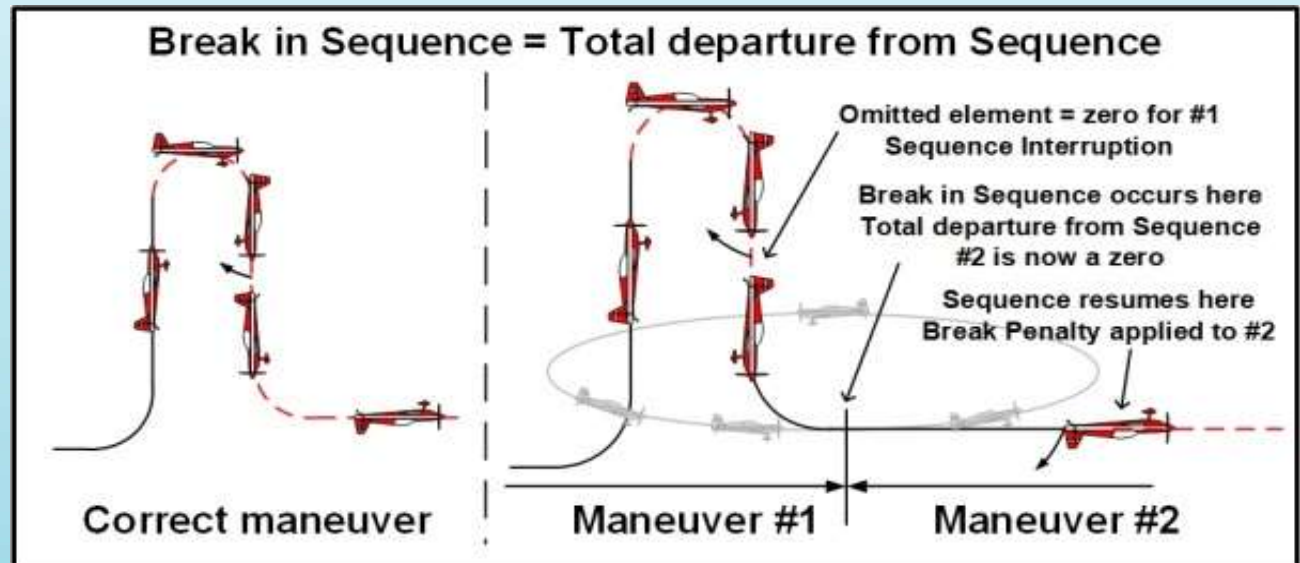

*If part of the maneuver is either omitted or added, maneuver #1 must be zeroed. IF a Break in Sequence occurs at the start of #2, it is also a zero and #2 will be the re-entry figure of the sequence and a Break Penalty is applied.*

# Judging Principles



## 6. Grading Principles:

### 6.3 Zeros continued

- Flying a figure in the wrong direction on the X-axis. The Y-axis is non-directional.
- Any cumulative deviation or error in excess of 90 degrees in the roll, pitch or yaw axes not related to wind corrections.
- Any figure or figures started and flown completely or partially on the pilot side of the deadline. The aircraft must clearly penetrate the deadline to receive a zero.

# Judging Principles



## Basic Components of Aerobatics

### 7.1 - Lines

- ❑ All lines are judged in relation to the true horizon and the axes of the aerobatic airspace.
- ❑ All lines are judged on flight path and must be wind corrected.
- ❑ All figures begin and end with a horizontal line of at least one fuselage length: Omitting the horizontal line between figures results in a line omission deduction of 1 point from the preceding **and** following figure (see Fig. 11).

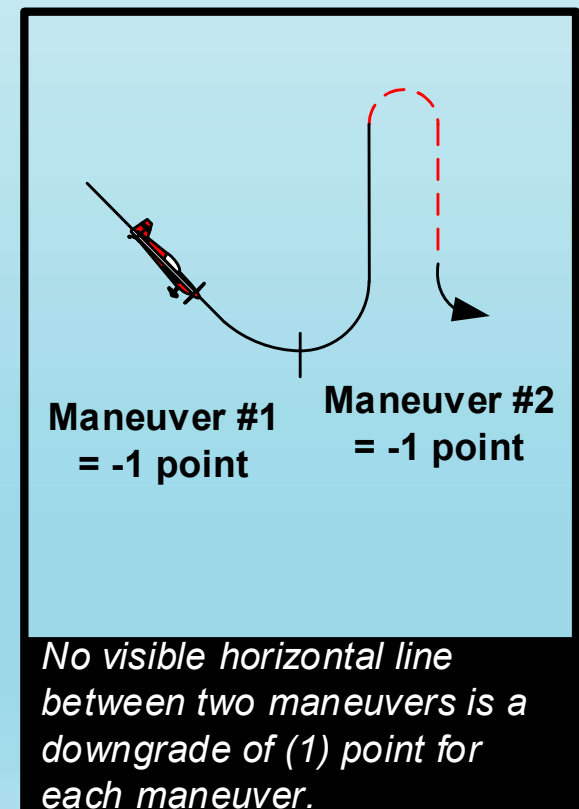

# Judging Principles



## Basic Components of Aerobatics

### 7.1 – Lines continued

- ❑ Interior Lines: All lines that occur inside a figure are preceded and followed by part-loops. The part loops are the beginning and end that define the line length.
- ❑ Except Family 3 figures and some Family 7 figures, interior lines do not have to be equal in length.
- ❑ Judges need to be familiar with the line length criteria for different figures and families.

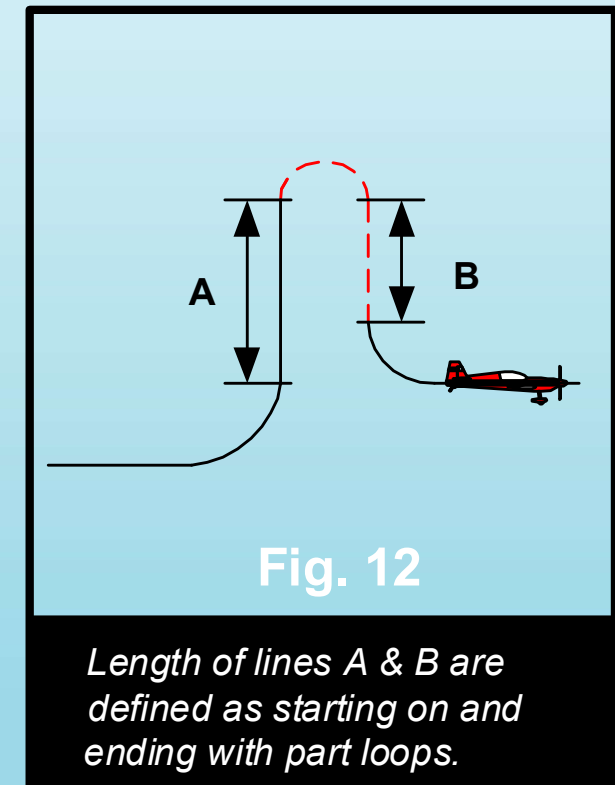

# Judging Principles



## Basic Components of Aerobatics

### 7.1 – Lines continued

- ❑ Rolls on Interior lines: When rolls are placed on interior lines the line segments before and after the roll must be of equal length.
  - Roll elements occurring after spins need not be centered.
- ❑ Judges must judge the symmetry of the line lengths within a figure, not elapsed time taken to fly each segment.
  - This difference in length versus elapsed time is most noticeable in figures where rolls are placed on up-lines. As the aircraft loses airspeed, the time it takes to fly a line after the roll will be greater than the time required to fly the line of the same length before the roll.

# Judging Principles



## Basic Components of Aerobatics

### 7.1 – Lines continued

If two or more lines within a figure must be of equal lengths, deductions are recorded via the following scale (Fig. 14):

- The first segment flown is the standard against which the other segments are judged.
- Visible variation: - 1 point
  - A 1:2 variation: - 2 points
  - Greater than 1:2 variation: - 3 points
  - No line before or after roll: - 4 points
  - No line before and after roll: - 2 points

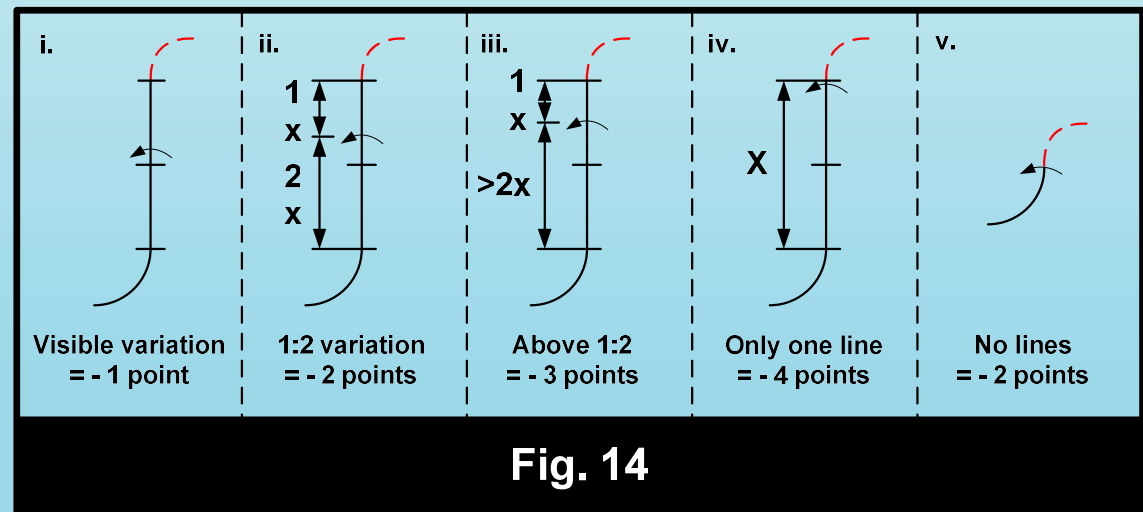

# Judging Principles



## Basic Components of Aerobatics

### 7.2 – Loops and Part Loops

Partial loops are integral to nearly all aerobatic figures. As such, it is necessary to discuss loops and part loops before going on to the Aresti families.

- A loop, or partial loop must have a constant, uninterrupted radius.
- Complete loops start and end in a well-defined line from horizontal flight.
- Part-loops may begin in any other plane of flight.

# Judging Principles



## Basic Components of Aerobatics

### 7.2 – Loops and Part Loops

- ❑ **All loops and part loops must be wind corrected:** Judge flight path, not pitch or yaw attitude.

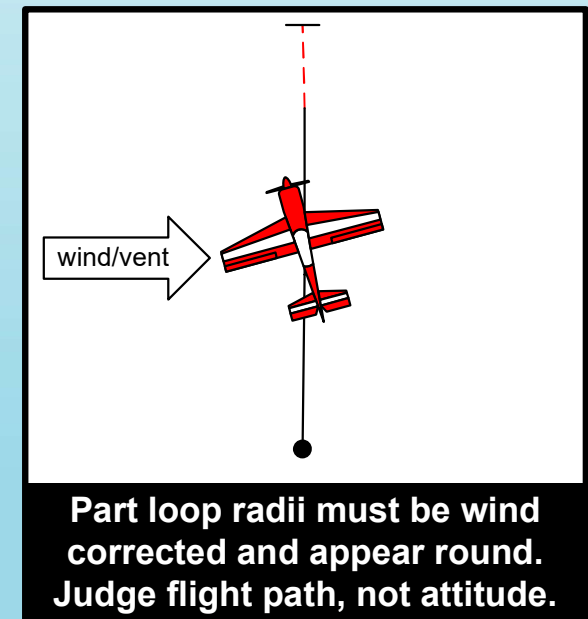
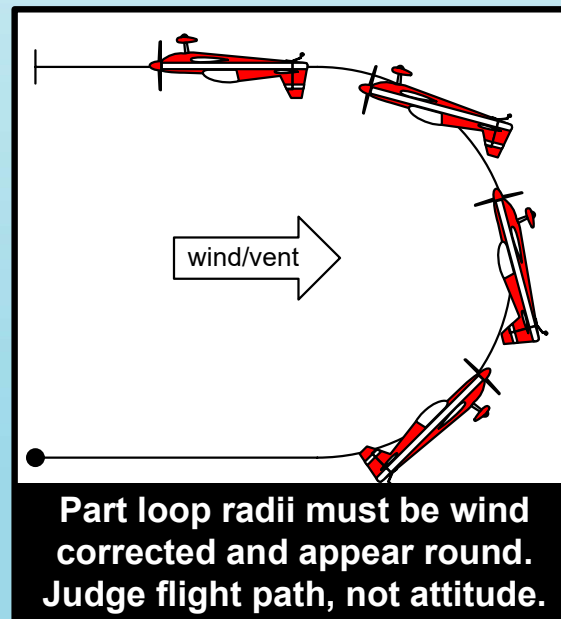
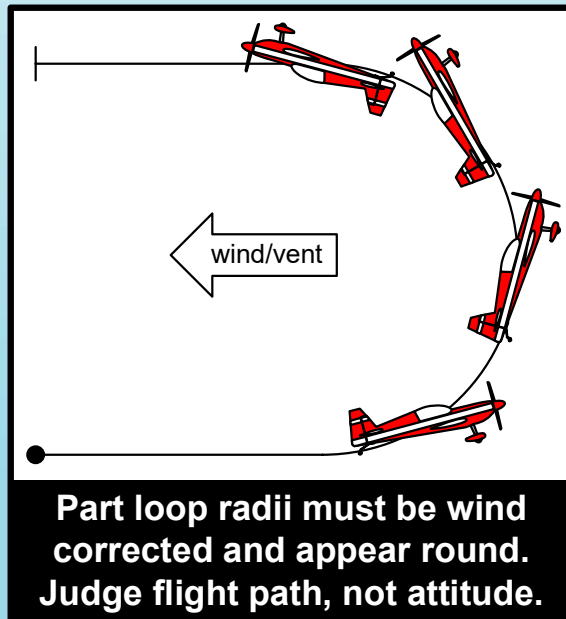



# Judging Principles



## Basic Components of Aerobatics

### 7.2 – Loops and Part Loops

- ❑ All loops and part loops must be of a constant and unchanging radius.
- ❑ All loops and part loops must scribe a radius that maintains a singular vertical plane: May not be “cork-screwed” or displaced laterally / perpendicularly from the established line of flight.
- ❑ Wind correction applies not only to the roundness of the loop or part loop, but also to track (effect of crosswind).

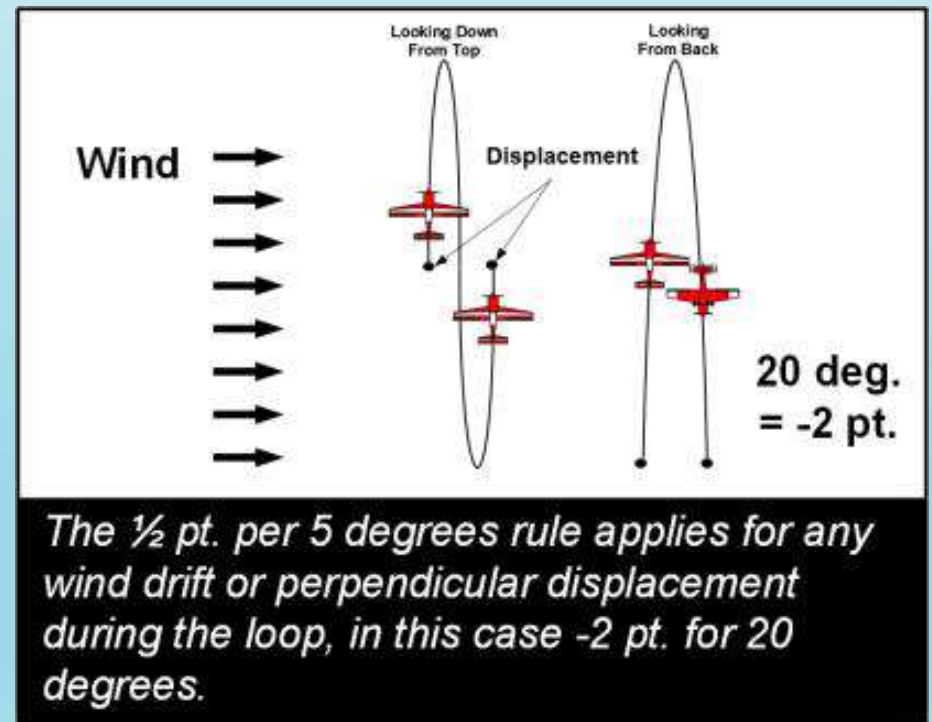

# Judging Principles



## Basic Components of Aerobatics

### 7.2 – Loops and Part Loops

- ❑ Partial loops in any one figure may or may not be required to have equal radii. When equal radii are required depends upon the figure in question and how it is drawn in the Aresti catalog.
- ❑ The quarter-loop radii in a vertical line (Family 1 figure) need not match (Fig. 15).
- ❑ Though A and B (Fig 16) need not match, they both must have a smooth, distinct, and constant radius.

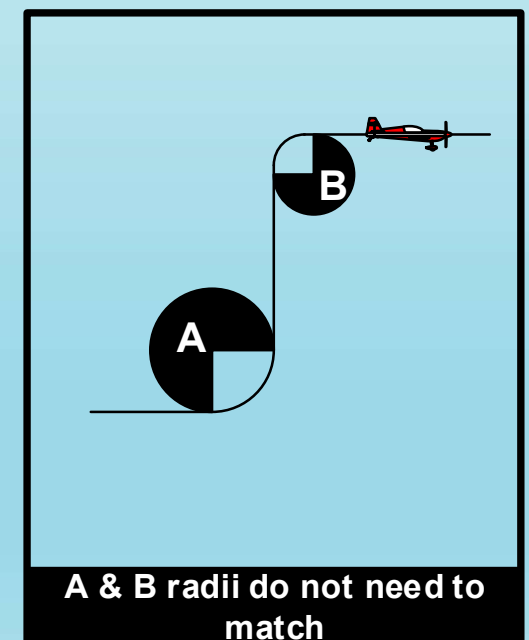
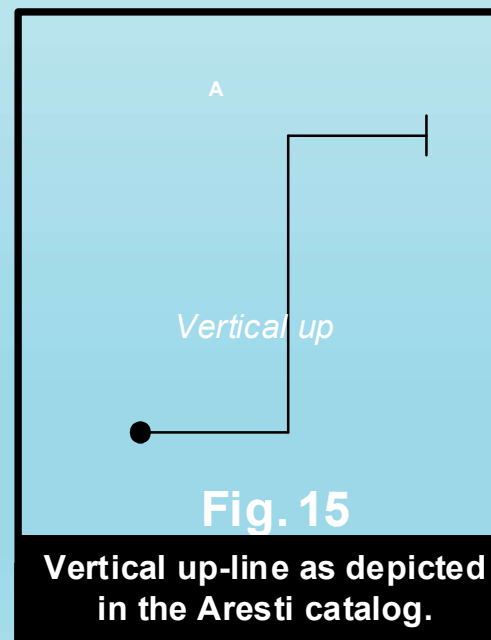

# Judging Principles



## Basic Components of Aerobatics

### 7.2.2a – Matching Radii

- ❑ Round Corners: For any figure in which more than one internal part-loop is depicted in the catalogue as a round, or looping line, all such part-loops **must** have the same radius.
- ❑ The exception being all of Family 8.8 (Double Humpty Bumps). For those figures, the radius of the second half-loop need not match the radius of the first. Thus the importance of knowing the specific grading criteria for all Aresti families.

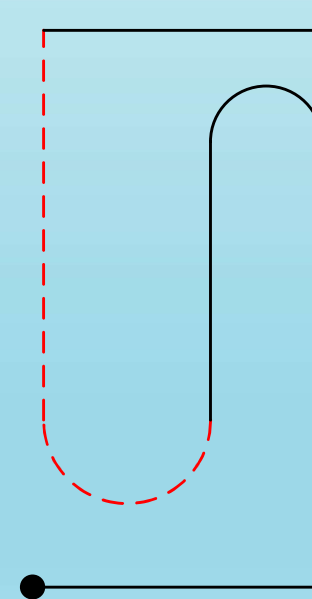
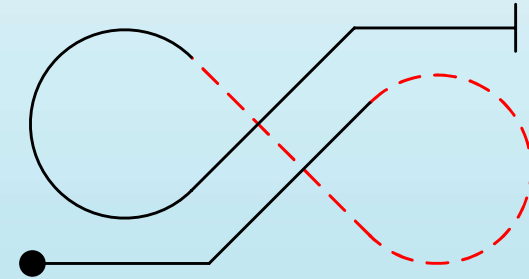

# Judging Principles



## Basic Components of Aerobatics

### 7.2.2b – Matching Radii

- ❑ Corner Angles: For any figure in which more than one internal part-loop is depicted in the catalogue with a hard, or corner angle, no such part-loop is required to match the radius of any other part-loop depicted in the same figure – with the exception of figures which must maintain a set geometric proportion, i.e.,

A) All of Family 3 (Combination of Lines)

B) Family 7.4.3.x to 7.4.6.x (Hesitation Loops)

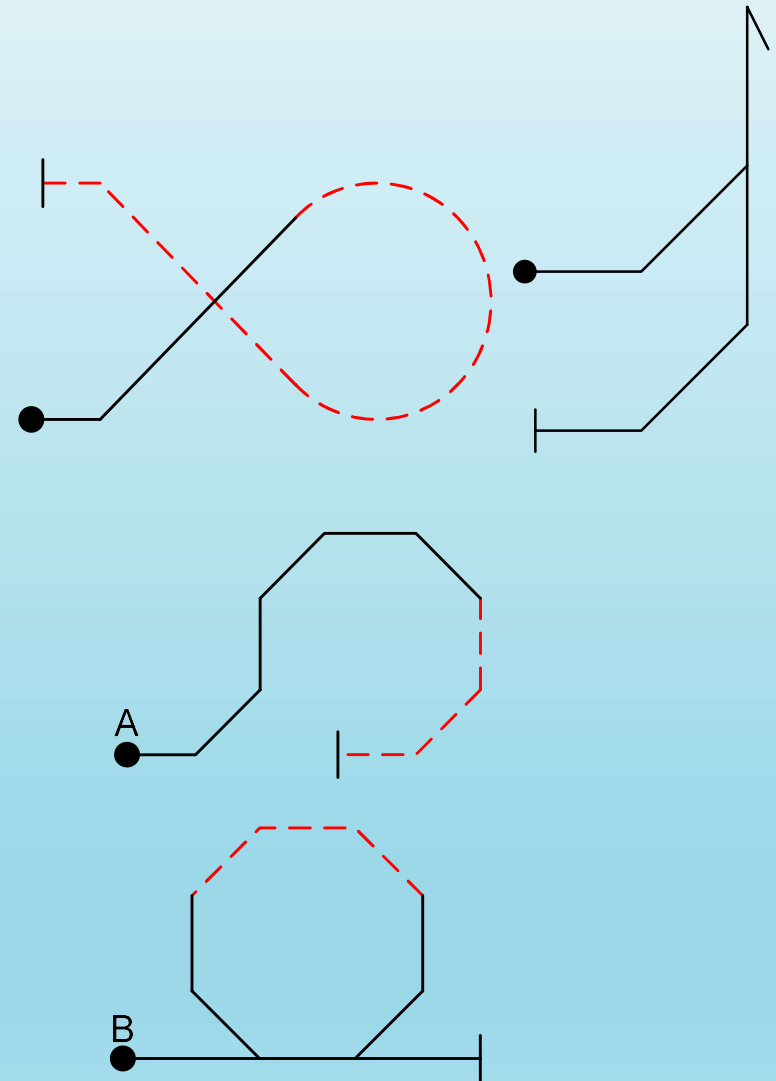

# Judging Principles



## Basic Components of Aerobatics

### 9.1. – 9.12. - Rotational Elements

- Roll rates must remain constant.
- Aircraft must maintain heading and prescribed plane and direction of flight during the roll.
- Aircraft must stop precisely after stated number of rotations.
- Roll elements on interior lines must be centered (equal length lines before and after the roll element).

Note: These are the basic requirements for all rotational elements. Specific judging criteria for each type of rotational element will be covered in depth in Family 9.



# Aresti System Families



# Aresti System Families 1 – 9

8.1 – 8.9.5

- Family 1 – Lines & Angles
- Family 2 – Turns & Rolling Turns
- Family 3 – Combinations of Lines
- Family 5 – Hammerheads
- Family 6 – Tail Slides
- Family 7 – Loops
- Family 8 – Combinations of Lines, Loops, & Rolls
- Family 9 – Rotational Elements

# Judging Criteria



## Family 1: Lines and Angles

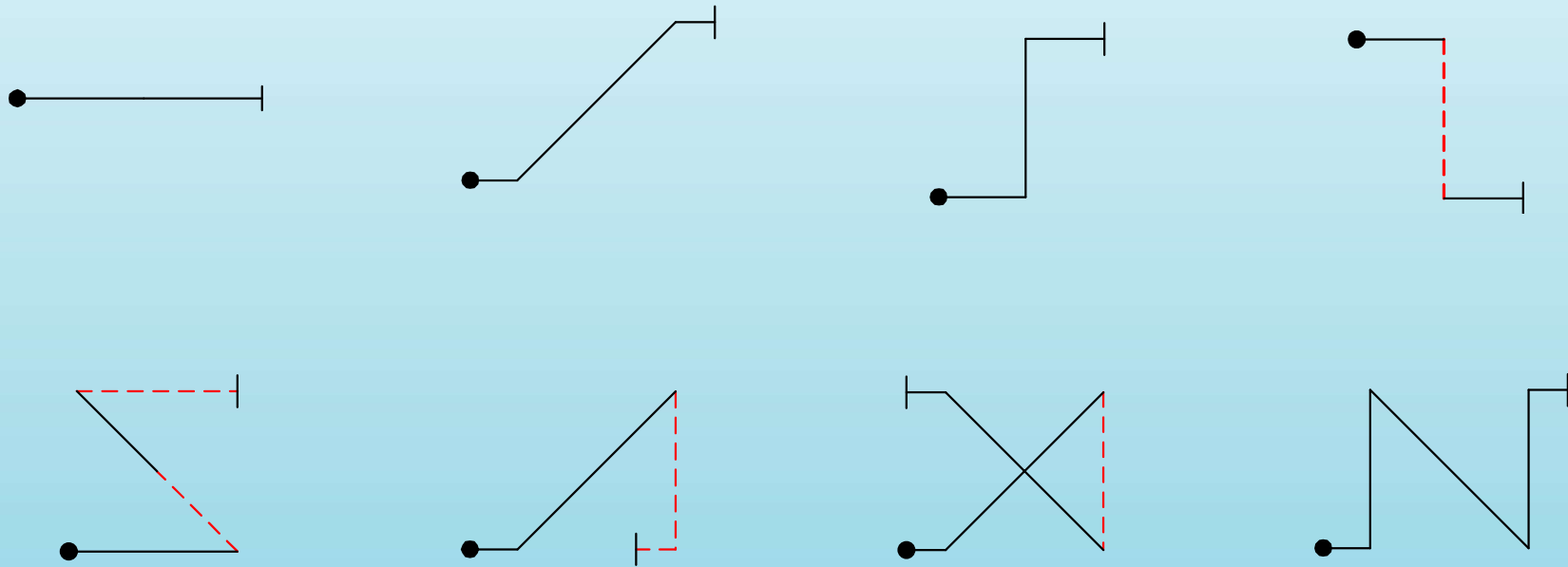

Note: These are examples of Family 1 base figures as they appear in the Aresti catalog. Some require added roll elements in order for the figure to be mechanically correct.



# Judging Criteria



## Family 1 (continued)

### Deductions for Roll Elements on Lines

- 1 point - visible variation
- 2 points - 2:1 variation
- 3 points - greater than 2:1 variation
- 4 points – no line before OR after roll
- 2 points - no line before AND after roll.

\*\*\* Always refer to Figure 14 / 14a\*\*\*

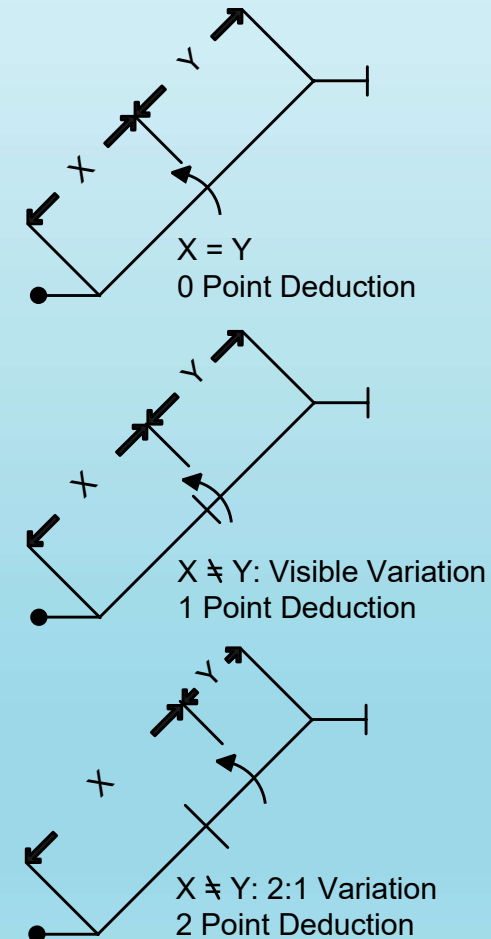

Fig 14a

# Judging Criteria



## Family 1 (Continued)

### Entry / Exit Radii, Line Lengths

- Radii need not be equal: No downgrade if not equal.
- Lines judged on flight path: - ½ point per 5°.
- If present, rolls must be centered: -1 to -4 pts (Fig 14).
- Exit altitude may be higher or lower than entry altitude.

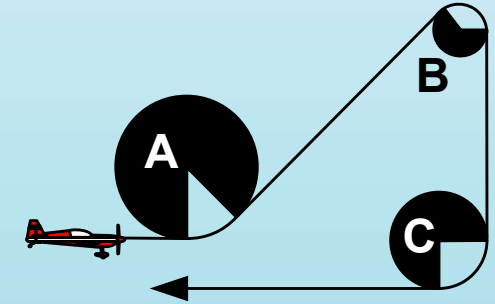

a <> b <> c

# Judging Criteria



## Family 1 (Continued)

### Review

- Track/Flight Path deviation.
- Roll elements centered.
- Distinct horizontal lines between figures of one fuselage length or more.
- Figure part loops do NOT have to be same radius.
- Cumulative grading criteria of each component.
- Any deviation of greater than 90° will result in a zero.
- Length of lines is NOT a grading criterion.
- Size of loops and part loops is NOT a grading criterion.

# Judging Criteria



## Family 2: Turns and Rolling Turns

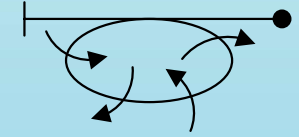
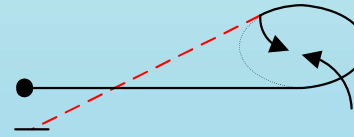
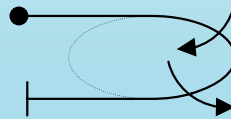
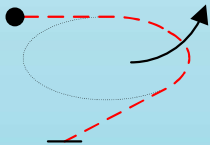
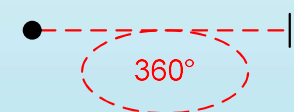
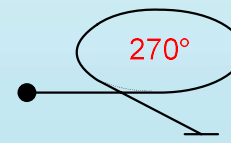
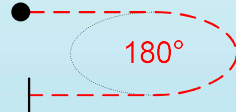
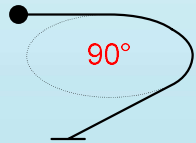

Note: These are examples of Family 2 figures as they appear in the Aresti catalog.

# Judging Criteria



## Family 2: Turns and Rolling Turns

### Turns

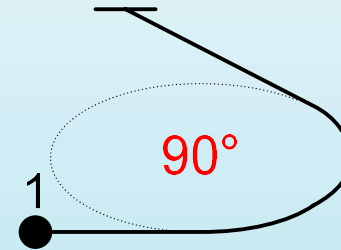

- Minimum bank angle of 60°, maximum of 90°: Downgrade is ½ point per 5°.
- Roll first, turn to heading, roll back to horizontal (bank then yank).
- Entry roll rate determines exit roll rate: - 1 point if not equal.
- Constant roll rate: - 1 point per occurrence.
- Constant rate of turn: - 1 point per variation.
- Constant altitude: - ½ point per 5°.
- More\*\*\*refer to the Flying & Judging Guide for complete criteria

# Judging Criteria



## Family 2: Turns and Rolling Turns

### Rolling Turns

- Constant rate of roll: - 1 point per occurrence.
- No stoppage: - 1 point per occurrence, (except figures where rolls alternate directions).
- Constant rate of turn: - 1 point per occurrence.
- Constant altitude : - ½ point per 5°.
- In opposite rolls, roll must be completed at wings level before reversal.
- Minimal pause, as in hesitation rolls, between opposite rolls.
- Correct number and direction of rolls: Zero if incorrect.

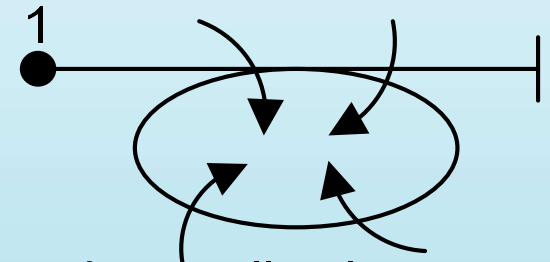

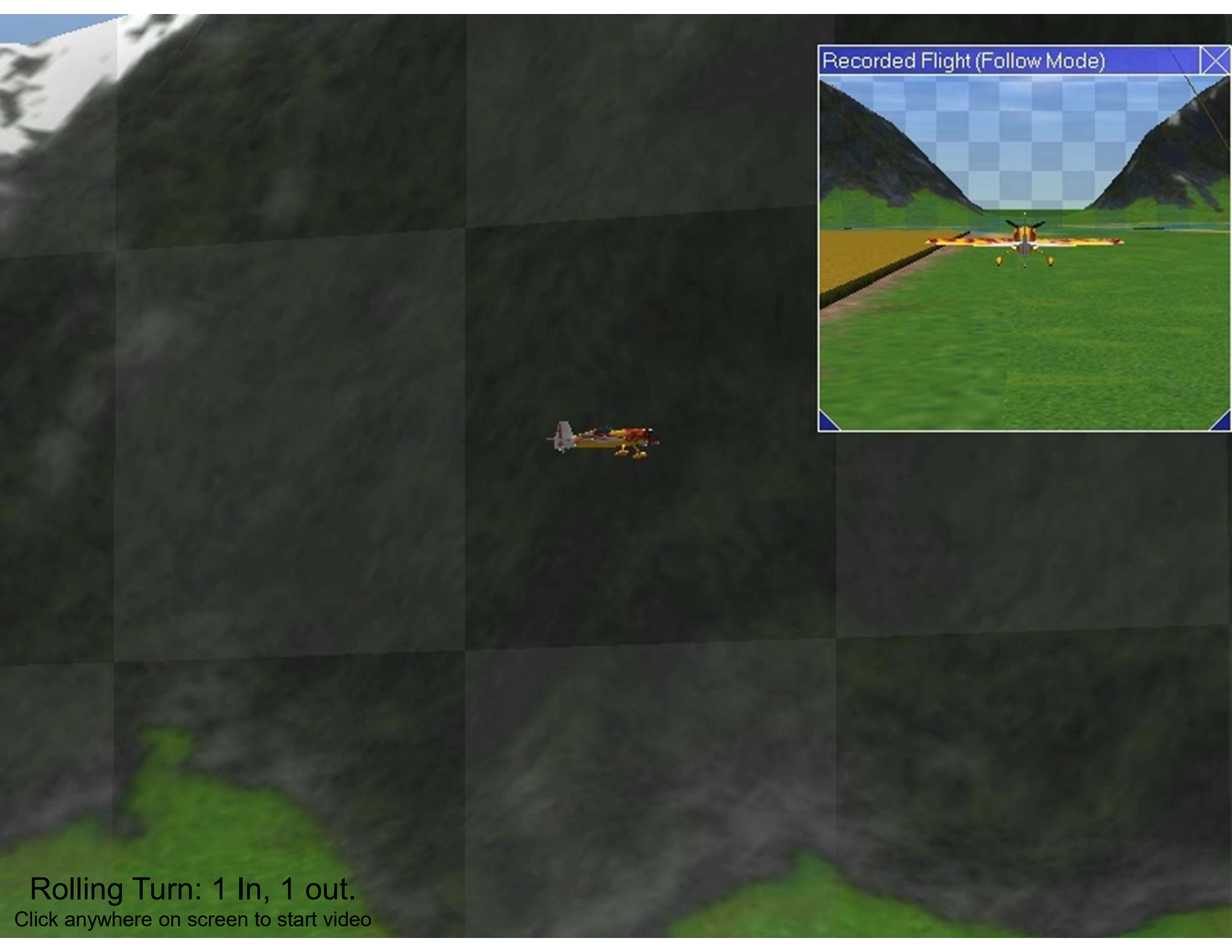

Rolling Turn: 1 In, 1 out.  
Click anywhere on screen to start video

# Judging Criteria



## Family 3 – Combination of Lines

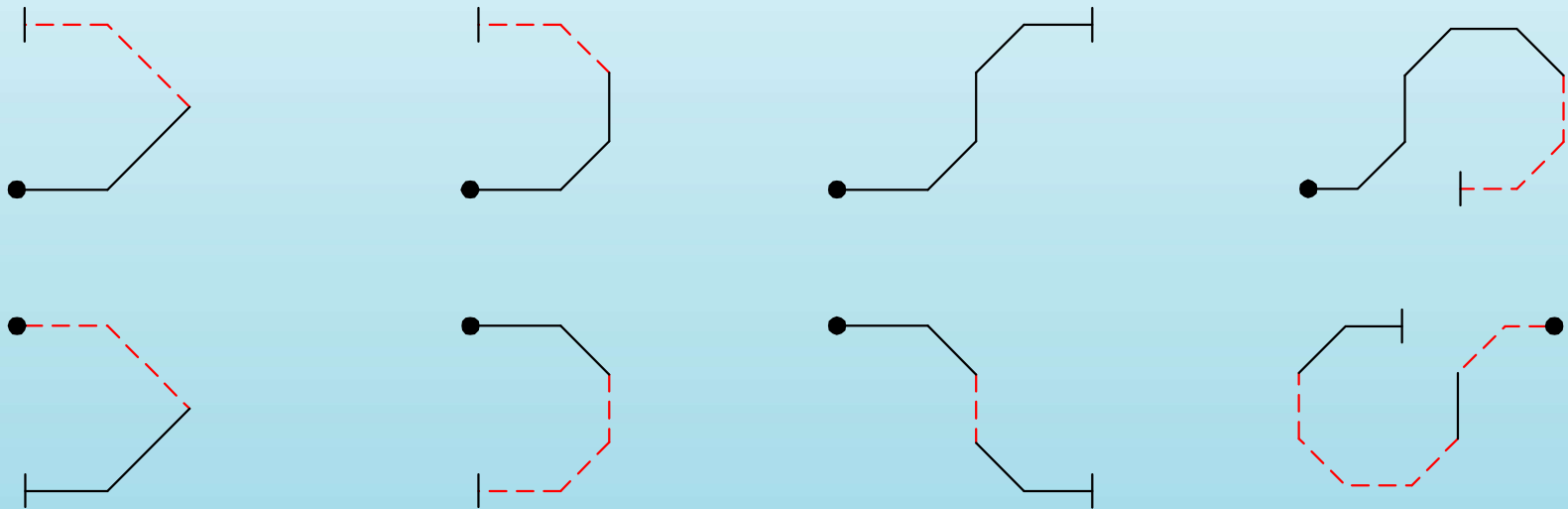

Note: These are examples of Family 3 base figures as they appear in the Aresti catalog. Family 3 figures never have roll elements added to them.



# Judging Criteria



## Family 3 – Combination of Lines

- ❑ All part-loop radii must be equal, - 1 point for each radius that is different from the first part loop: Loop Rules apply.
- ❑ Lines within the figure must be equal in length.
- ❑ The first line establishes the length of the rest. Refer to rule 7.1 for line downgrades.
- ❑ Lines judged on flight path: -  $\frac{1}{2}$  point per  $5^\circ$ .

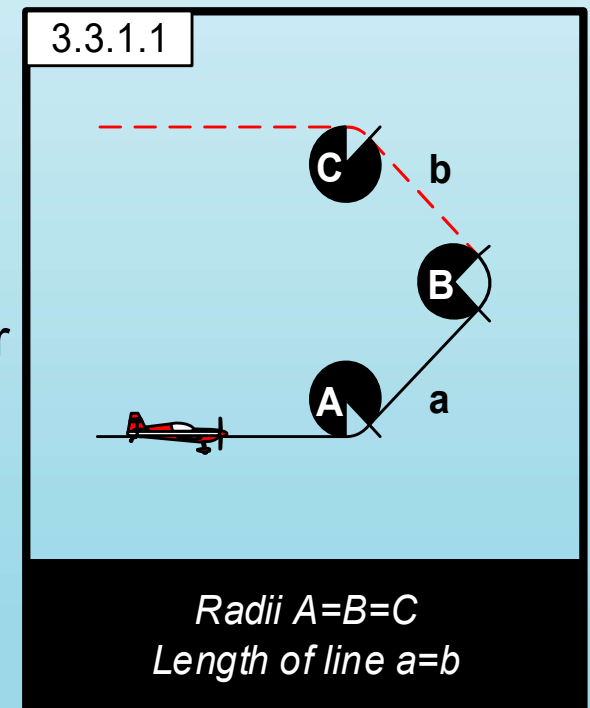

# Judging Criteria



## Family 5 – Stall Turns (Hammerheads) 2 lines, 3 lines, and 4 lines.

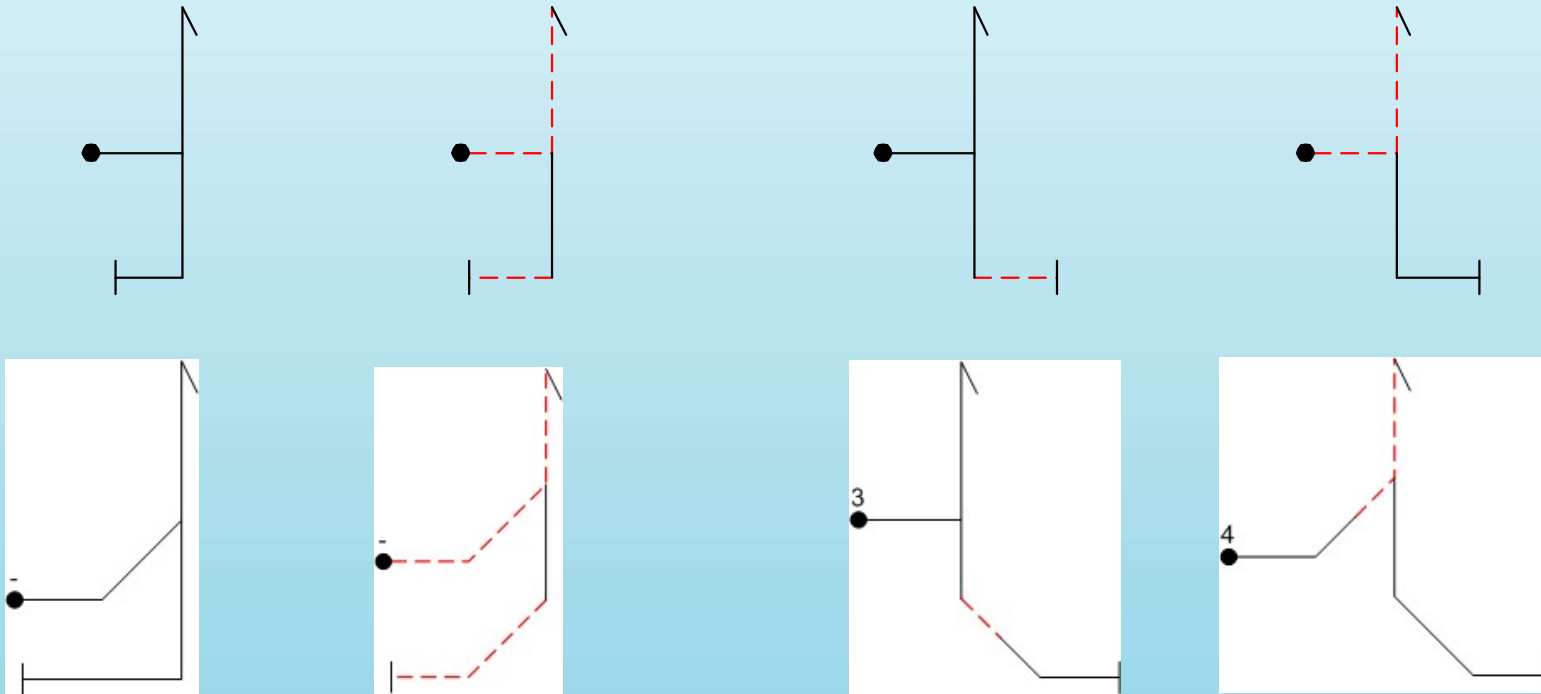

Note: These are examples of Family 5 base figures – 2, 3, and 4 line hammerheads - as they appear in the Aresti catalog. Any of the lines may have added roll elements.

# Judging Criteria



## Family 5 – Stall Turns (Hammerheads)

- ❑ Radii of part loops need not match; must be smooth and constant - Loop Rules apply.
- ❑ All lines, vertical or 45 degree, must be wind corrected and flown as straight lines at the correct angle to the horizon: - 1/2 point per 5° error.
- ❑ Lines lengths before and after any rolls must be equal: -1 to -4 pts (Figure 14).
- ❑ Yaw axis pendulum movement observed after the pivot is subject to downgrade at 1/2 point per 5°.

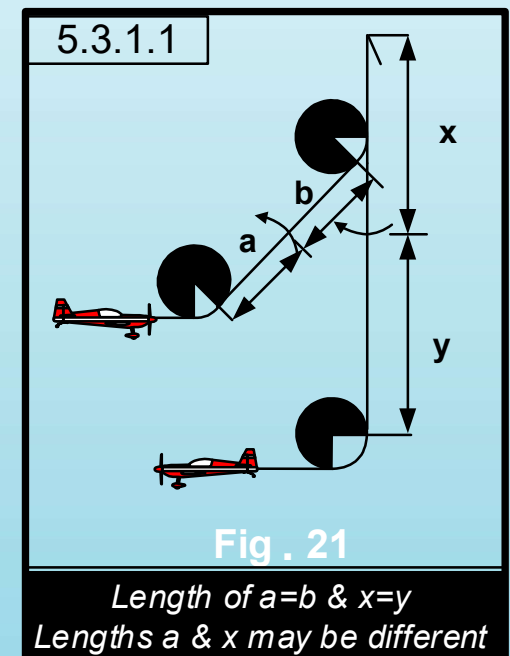

# Judging Criteria



## Family 5 – Stall Turns (Hammerheads)

Aircraft should pivot no farther away than the wingtip while maintaining a vertical plane: -  $\frac{1}{2}$  point per  $5^\circ$  for “torquing off” the top ( $>90^\circ$  = zero).

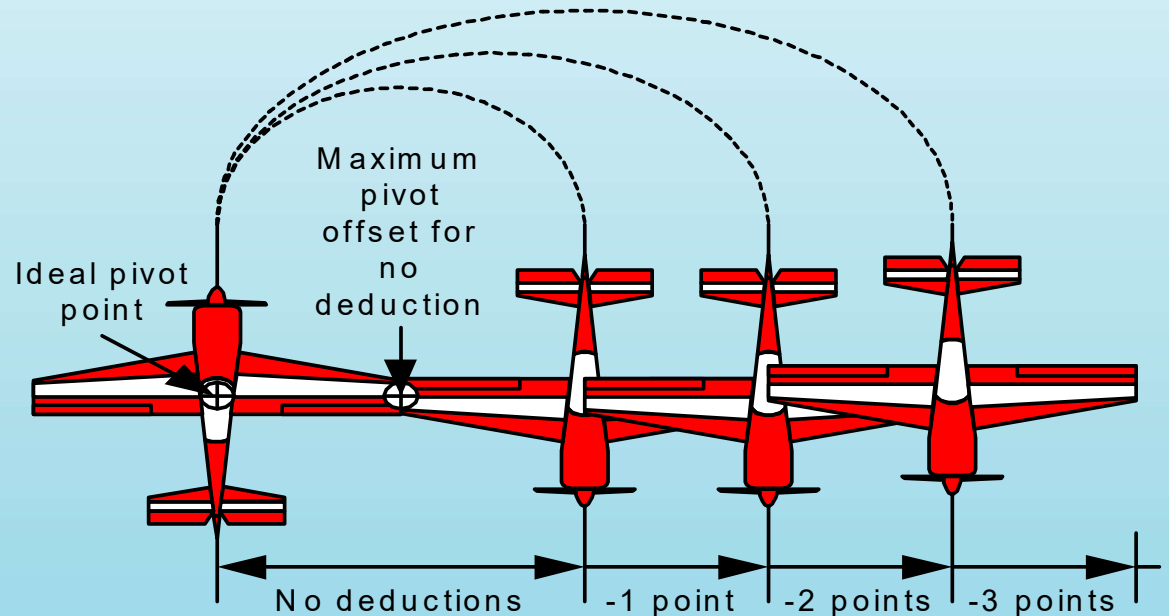

*Deduct 1 point per  $\frac{1}{2}$  wingspan over the maximum offset point.*

# Judging Criteria



## Family 5 – Stall Turns (Hammerheads)

- Zero if aircraft “flops.”
- Zero if “flyover” (Going up/horizontal +4 wingspans).
- Zero if any visible backward movement **prior** to pivot - aircraft “slides.”
- Line length is not a grading criterion.
- Entry and exit altitude may be different.

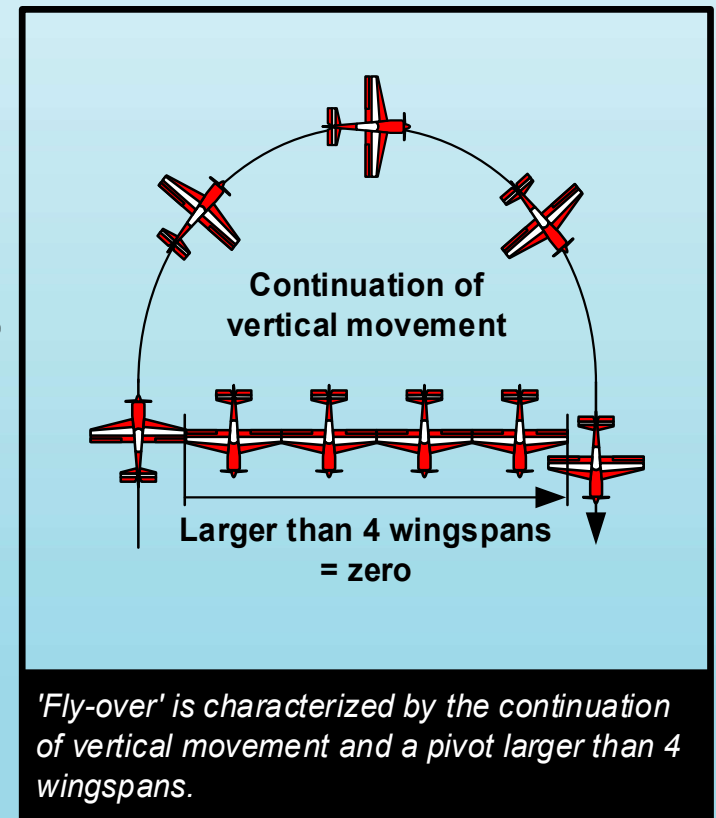

# Judging Criteria



## Wind Considerations

- ❑ From level flight, aircraft establishes wind-corrected vertical line.
- ❑ As the aircraft approaches the stall, transitions to perfectly vertical in the PITCH axis only.
- ❑ During pivot, only yaw should be present, and the aircraft may be displaced due to wind (no downgrade).
- ❑ Immediately after completing the turnaround and establishing flying speed, wind correction is reapplied.
- ❑ Aircraft pulls out to level – entry radius and exit radius can be different.

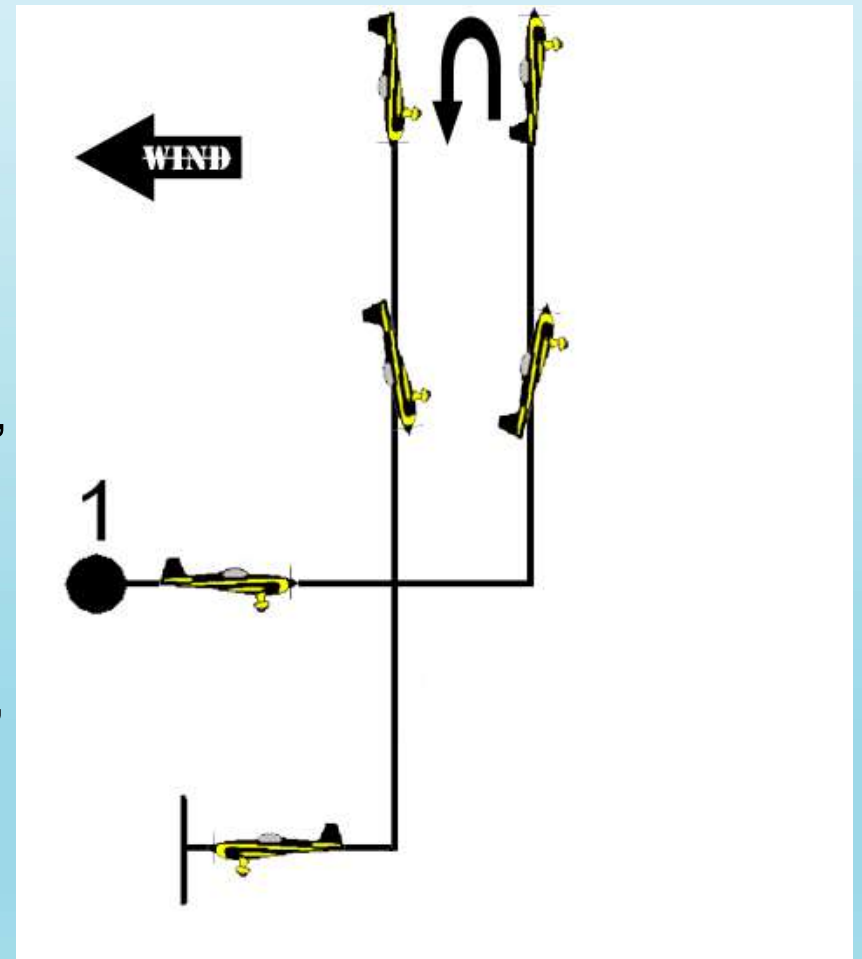

# Judging Criteria



## Family 6 – Tail Slides

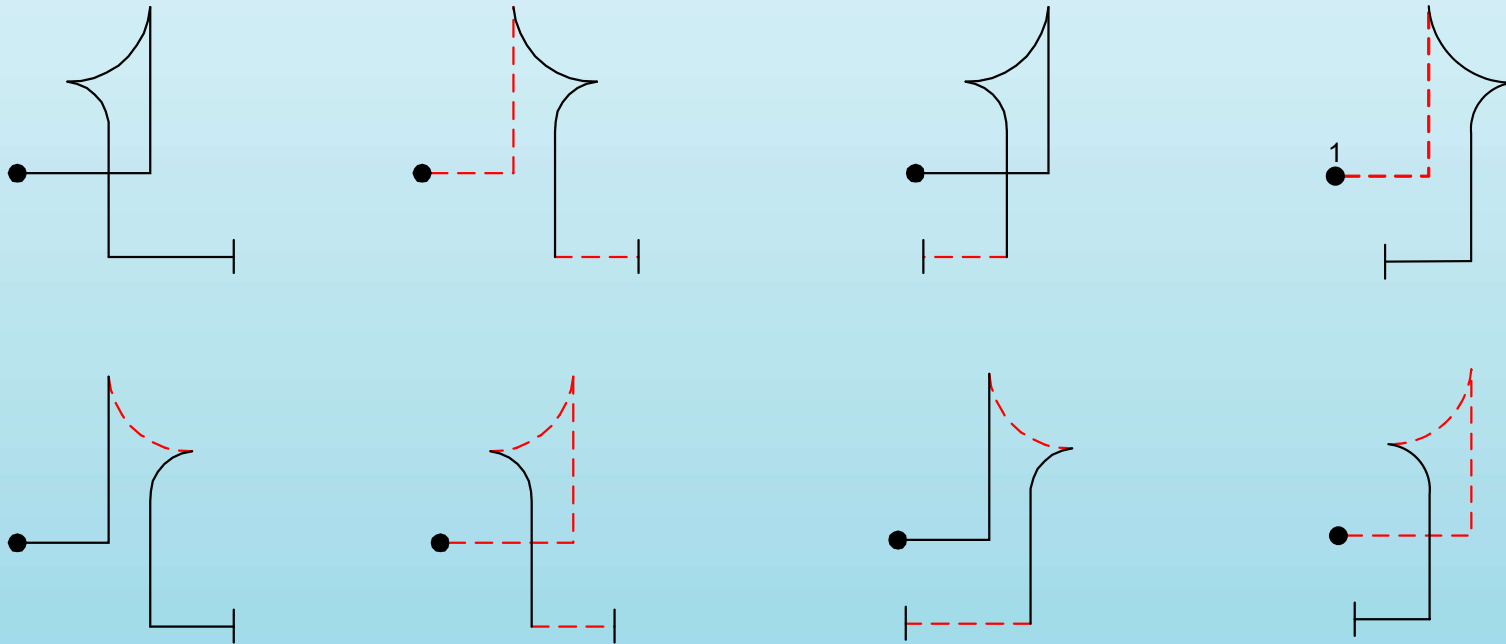

Note: These are examples of Family 6 base figures – tailslides - as they appear in the Aresti catalog. Roll elements may be placed either or both of the vertical lines.

# Judging Criteria



## Family 6 – Tail Slides

- ❑ Entry / exit part loop radii need not match; must be smooth and constant: Loop Rules apply.
- ❑ Track up and down must be vertical:  $-1/2$  point per  $5^\circ$ .
- ❑ Lines before and after any rolls must be equal: -1 to -4 pts (Figure 14).
- ❑ Aircraft must slide backwards a visible amount.
- ❑ Zero the figure if no backward movement (watch the tail), always give the competitor the benefit of the doubt.

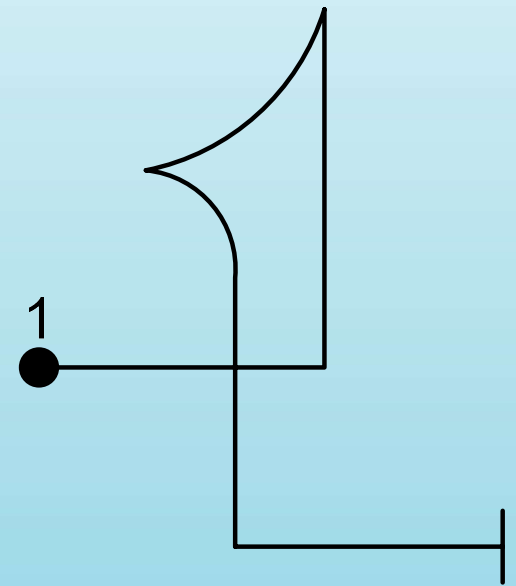



# Judging Criteria



## Family 6 – Tail Slides

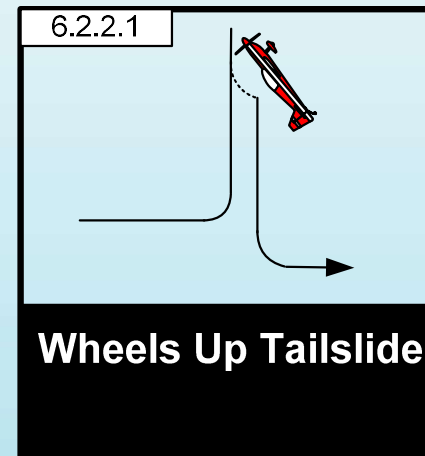
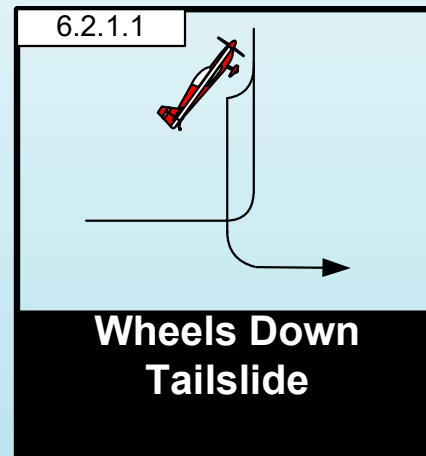

- Aircraft must fall in direction as indicated by the Aresti drawing (wheels up/down): Zero if wrong direction.
- Aircraft must fall with wings level in correct plane:  $-1/2$  point per  $5^\circ$ .
- No downgrade for pendulum after slide. (However aircraft must re-establish vertical down line).
- Entry / exit altitude may be different.

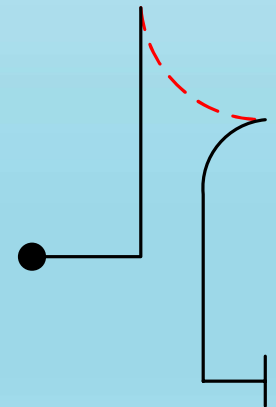
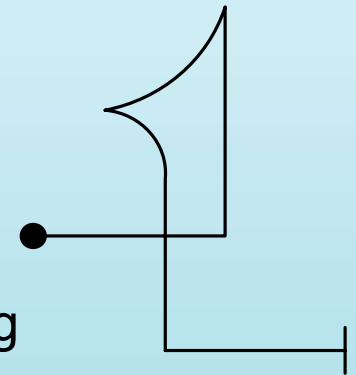

# Judging Criteria



## Family 6 – Tail Slides

### Wind Implications

#### Downwind Tail Slide

Horizontal wind drift away from the judge can appear as backwards slide, even if none is present due to a change in viewing angle.

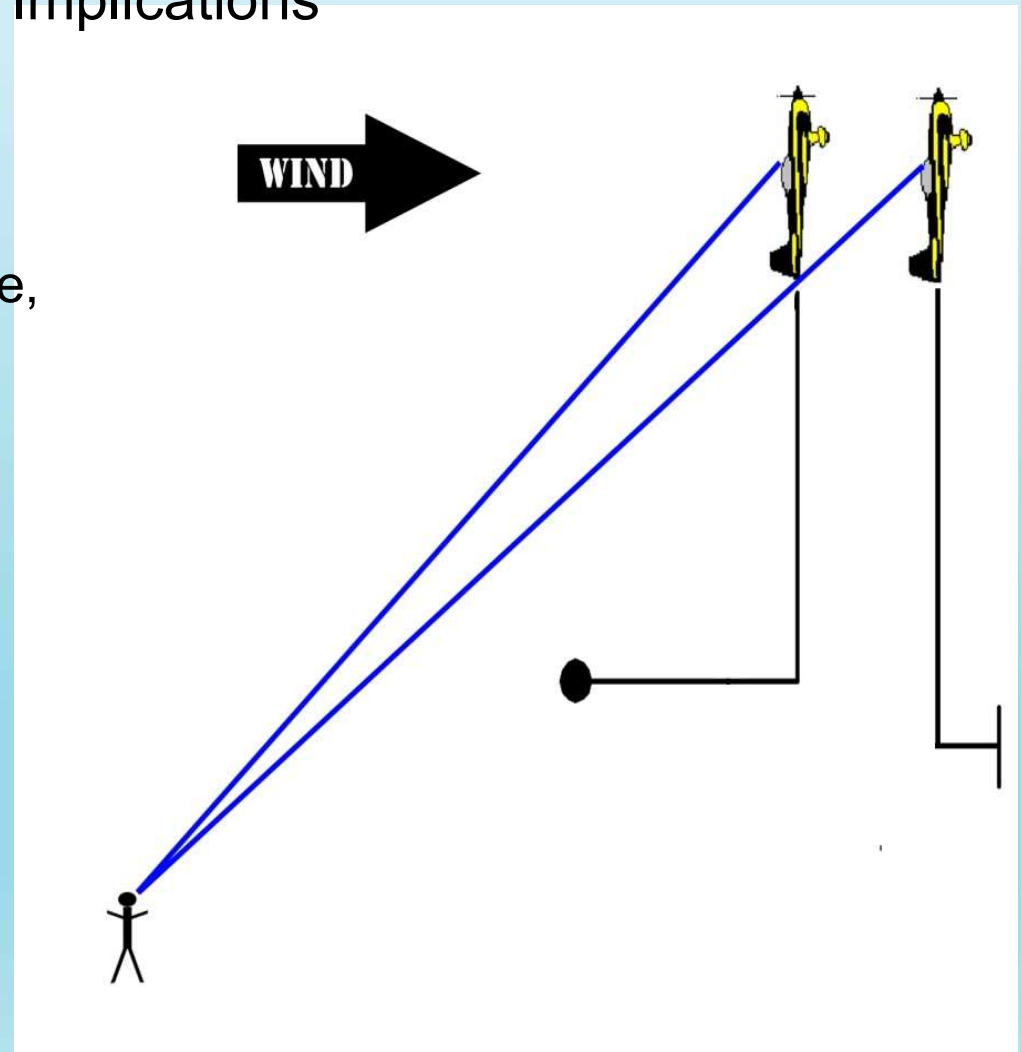

# Judging Criteria



## Family 6 – Tail Slides

### Wind Implications

#### Upwind Tail Slide

Wind drift **towards** the judge can actually hide a true backwards displacement if the viewing angle changes very little from the judge's perspective.

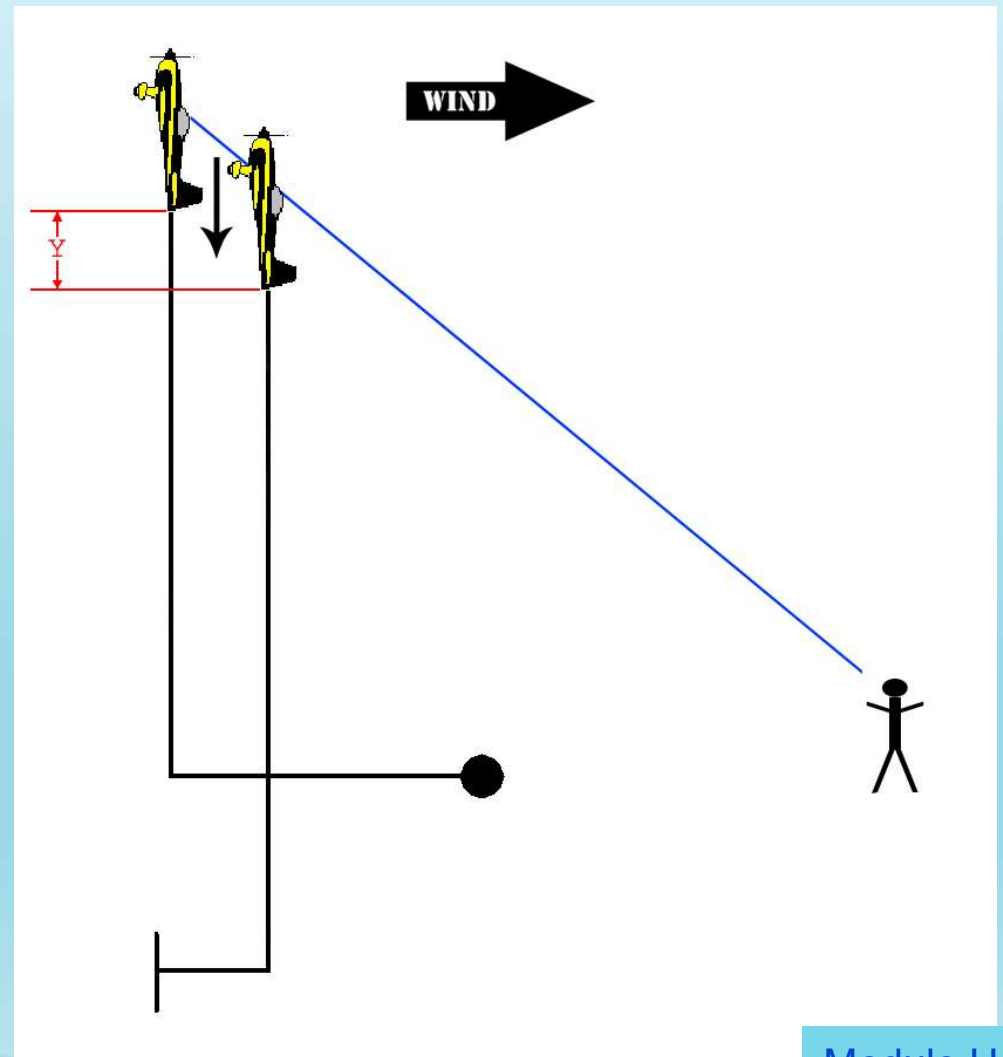

# Judging Criteria



## Family 7 – Loops and Eights

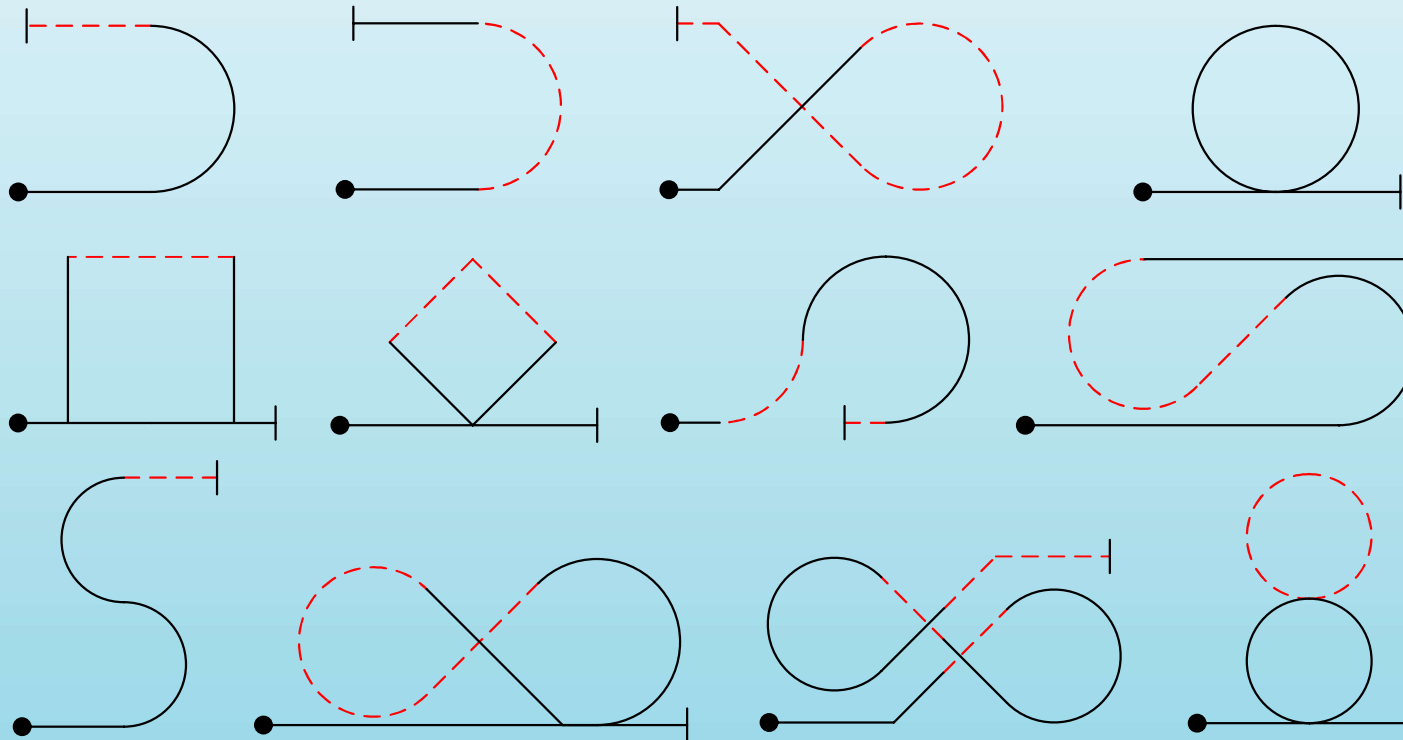

Note: These are examples of Family 7 base figures – Loops and Eights - as they appear in the Aresti catalog. Roll elements may be placed on interior lines, immediately prior to or after a part loop radius, or integrated into the loop radius in some figures.

# Judging Criteria



## Family 7 – Half Loops (7.2.1.x - 7.2.4.x) “Immelmann” & “Split-S” Loops

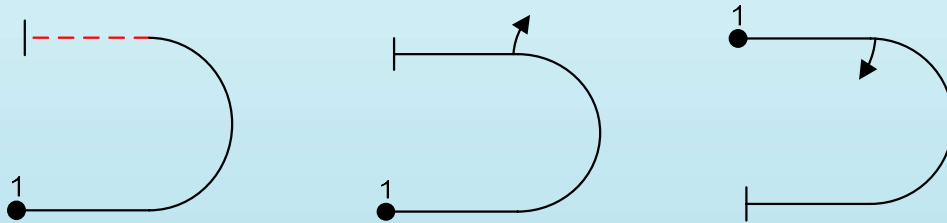

- ❑ Any lateral displacement:  $-1/2$  point per  $5^\circ$ .
- ❑ Any variation in radius: -1 point per occurrence.
- ❑ Any Roll displacement (other than during a roll element on the loop):  $-1/2$  point per  $5^\circ$  of roll.
- ❑ Flight path without any radius (straight line or flat spot): -1 point per occurrence.
- ❑ If rolls are present, there must be no visible line between the start/end of loop and roll: -2 point if visible line, could be zeroed at judges discretion if appears as two separate maneuvers.

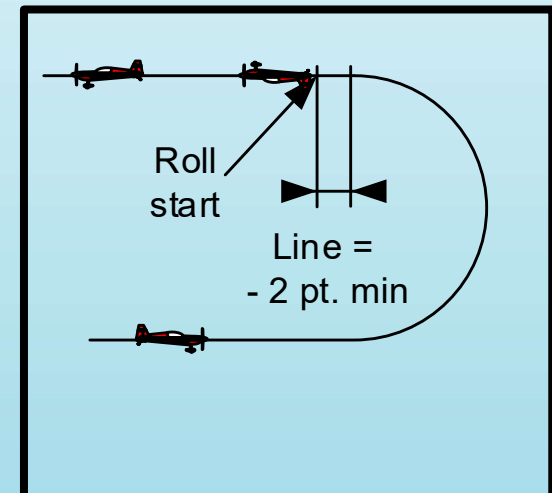

*Drawing a line after the 1/2 loop is a minimum downgrade of 2 points.*

# Judging Criteria



## Family 7 – Three Quarter Loops (Goldfish) Loops (7.3.1.x-7.3.4.x)

- ❑ Entry and exit radii need not match - All loop rules apply.
- ❑ Three Quarter Loop does not have to match entry or exit 1/8 loops – Loop rules apply.
- ❑ Length of 45° lines is not a grading criterion.
- ❑ Any rolls on 45° lines must be centered: - 1 point for visible variation, etc. (length of line/roll criteria)
- ❑ 45° lines are judged on track: -1/2 point per 5° error.

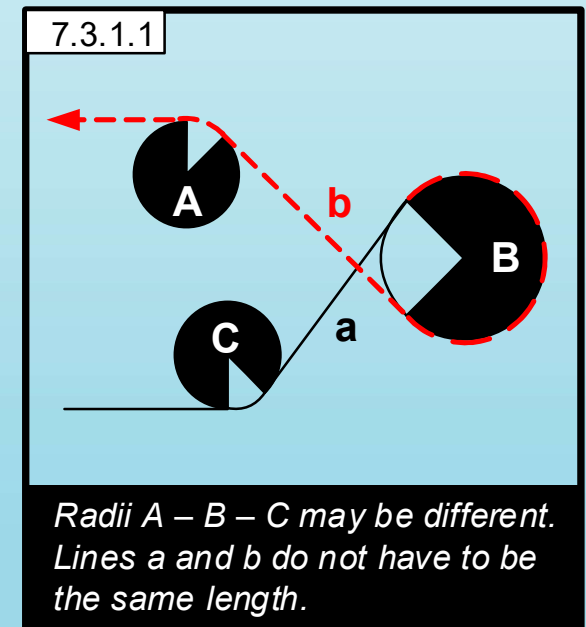
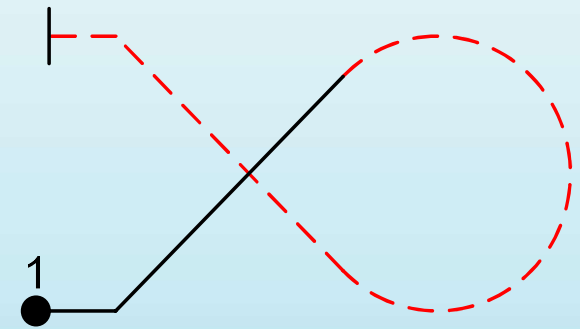

*Radii A – B – C may be different.  
Lines a and b do not have to be  
the same length.*

# Judging Criteria



## Family 7 – Whole Loops (7.4.1.x. – 7.4.2.x) Loops

- All loop rules apply.
- Must appear perfectly round.
- If there is displacement perpendicular to the flight line: - ½ point per 5°.
- Radius must be constant; wind corrected: Radius changes: -1 point per occurrence.
- Flat spot: -1 point per occurrence.
- If rolls are present, they must be centered at apex, or at the bottom of the loop.
- At least -2 points if flown on a line (not in radius).

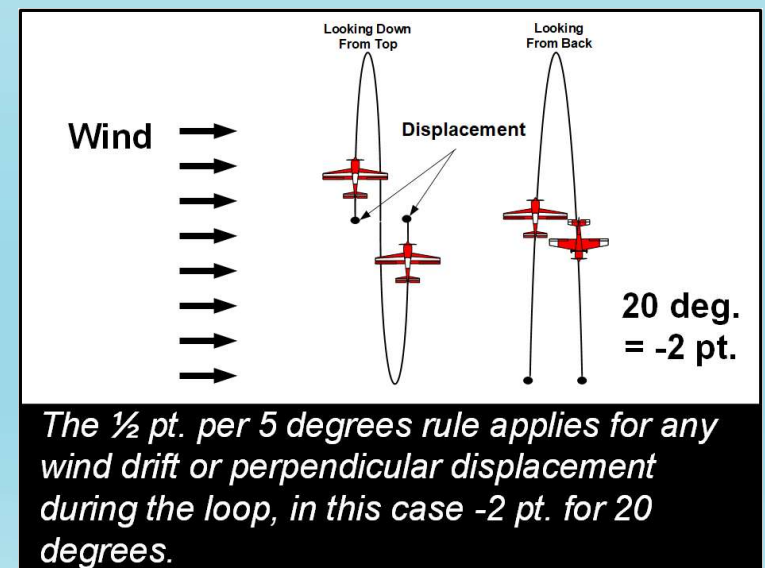
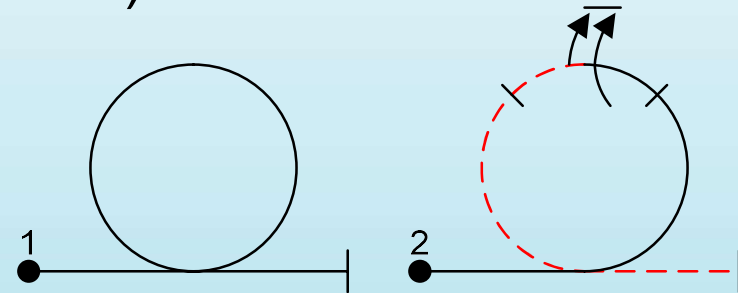

# Judging Criteria



## Family 7 – Whole Loops (7.4.3.x. - 7.4.6.x) Loops (Square, Diamond & Octagon)

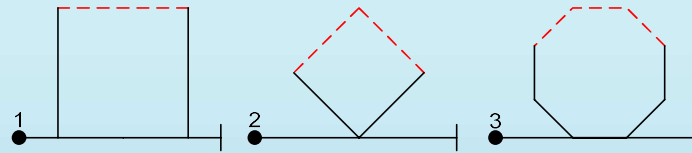

- ❑ Must begin and end at the same altitude.
- ❑ 90° and 45° lines are judged on track: -1/2 point per 5°.
- ❑ All radii must be constant and equal: -1 point for each radius that differs from the first part loop flown: Loop rules apply.
- ❑ All line segments must be of equal length: The first line sets the standard. Refer to line rules 7.1 for downgrades.
- ❑ If rolls are present, they must be centered on the line: -1 to -4 pts (Figure 14).

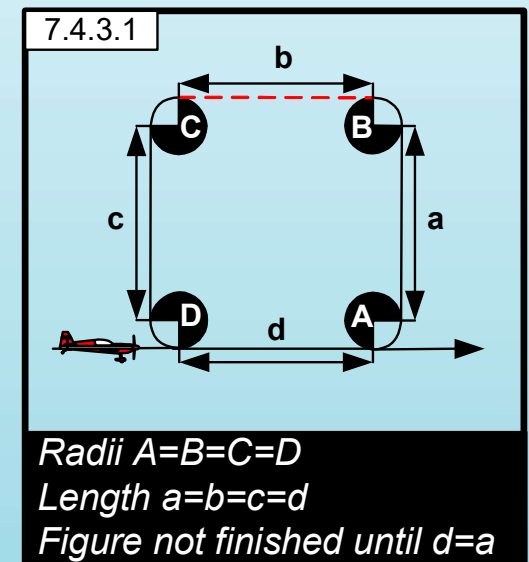



# Judging Criteria



## Family 7 – Reversing Whole Loops (7.4.7.x. - 7.4.14.x) Loops

- ❑ Radius must be constant: Radius changes: -1 point per occurrence.
- ❑ Radii of all looping segments must be equal.
- ❑ Must be no line between  $\frac{1}{4}$  &  $\frac{3}{4}$  loop segments: Minimum 2 point deduction.
- ❑ If rolls are present on the  $\frac{3}{4}$  loop, must be centered at apex / bottom: -2 points if flown on a line (not in radius).
- ❑ If rolls are present on entry or exit, there must be no visible line between the start/end of loop and roll: -2 point if visible line, could be zeroed at judges discretion if appears as two separate maneuvers.

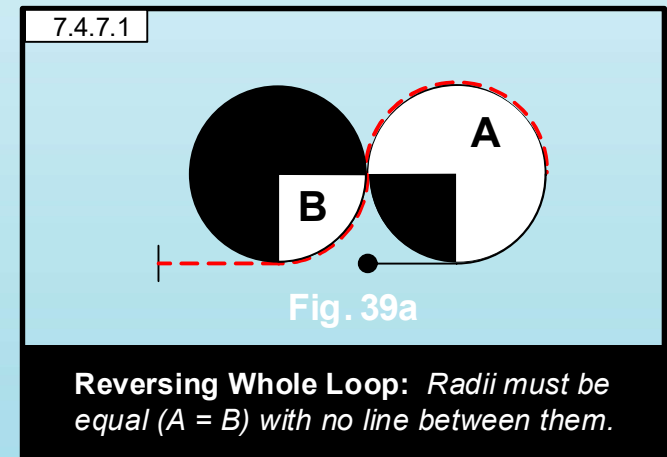

# Judging Criteria



## Family 7 – Horizontal S's (7.5.1.x-7.5.8.x) Loops

- ❑ 5/8 loop radii must be equal: -1 point if different.
- ❑ All loop rules apply.
- ❑ Rolls elements on 45° lines must be centered: -1 to -4 pts (Figure 14).
- ❑ 45° lines are judged on track: -½ point per 5°.
- ❑ If rolls are present on the horizontal lines, there must be no visible line between the start/end of loop and roll: -2 point if visible line, more if line is extended and may be zeroed at judges discretion.

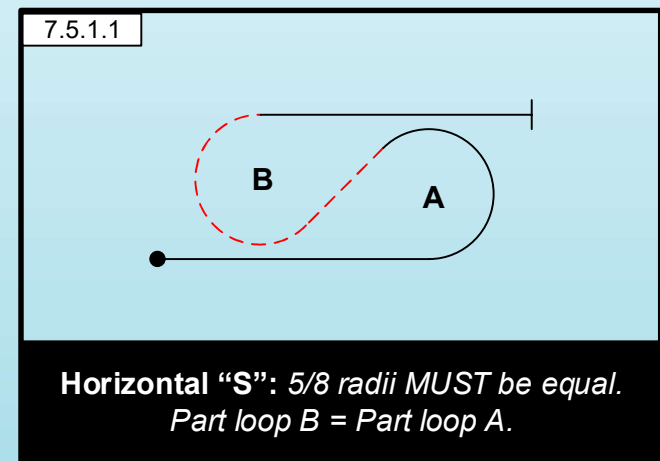

# Judging Criteria



## Family 7 – Vertical S's (7.5.9.x-7.5.10.x) Loops

- ❑ Both half loops must appear round and of equal size: -1 point if the two  $\frac{1}{2}$  loops are different.
- ❑ Loop rules apply: -1 point for each radius change.
- ❑ Flat spot: -1 point per occurrence.
- ❑ Wind corrected (Vertical plane):  $-\frac{1}{2}$  point per  $5^\circ$  error.
- ❑ Wings level:  $-\frac{1}{2}$  point per  $5^\circ$ .
- ❑ If half rolls are present, they must immediately follow the looping line and be flown on a horizontal line. No visible line may precede or follow the half roll: -2 points for line before or after.

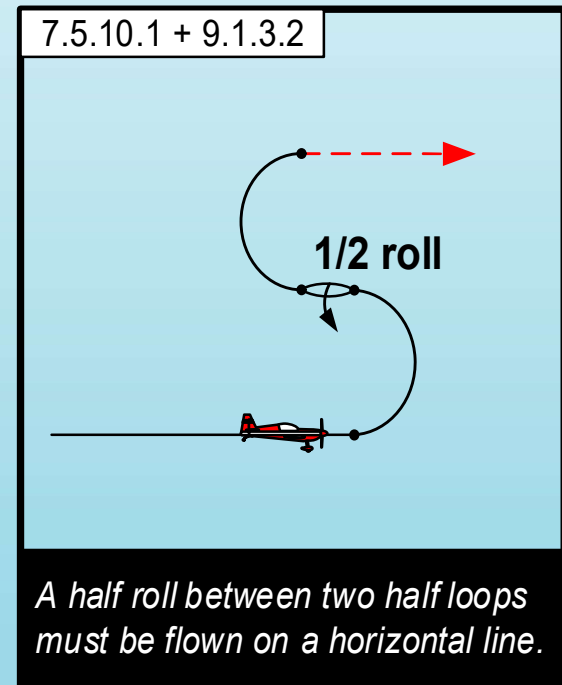

# Judging Criteria



## Family 7 – Horizontal 8's (7.8.1.x-7.8.8.x) Loops

- ❑ 5/8 & 3/4 Loop radii must be equal: -1 point if different.
- ❑ 1/8 entry or exit radii may differ from 5/8 & 3/4 loop radii.
- ❑ 45° Lines must be of equal length: line length rules apply (Fig 14).
- ❑ All roll elements on 45° lines must be centered: -1 to -4 pts (Figure 14).
- ❑ 45° lines are judged on track: -1/2 point per 5°.
- ❑ If rolls precede or follow the 5/8 loop entry or exit, there must be no visible line between the start/end of loop and roll: -2 point if visible line, may be zeroed at judges discretion if appears as two separate maneuvers.

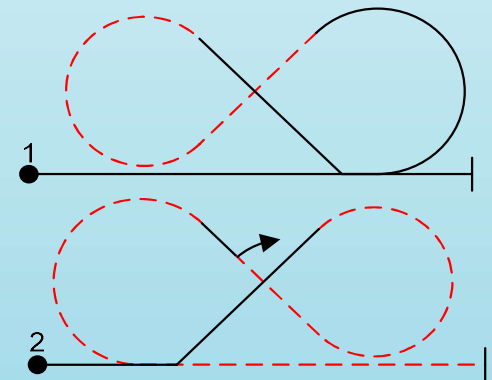

# Judging Criteria



## Family 7 – Horizontal Super 8's (7.8.9.x-7.8.16x) Loops

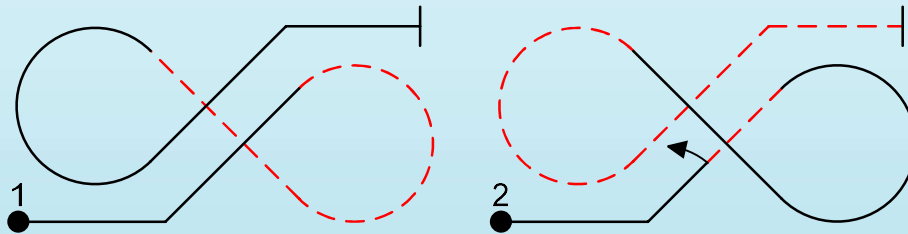

- ❑ Contain three 45 degree lines (which can all have rolls).
- ❑ 45 degree lines may be of different lengths.
- ❑ Entry and exit radii need not match, but must be smooth and constant - All loop rules apply.
- ❑  $\frac{3}{4}$  Loop radii must be equal: - 1 point if different.
- ❑ Entry & exit radii can be different from  $\frac{3}{4}$  loop radii.
- ❑ The  $\frac{3}{4}$  loops need NOT occur at the same altitude, nor is there any relationship between the entry/exit altitudes and the altitudes of the  $\frac{3}{4}$  loops.

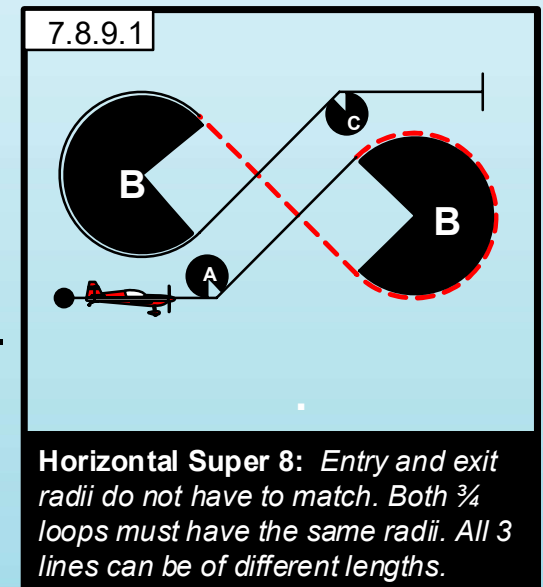

# Judging Criteria



## Family 7 – Vertical 8'S (7.8.17.x-7.8.22.x) Loops

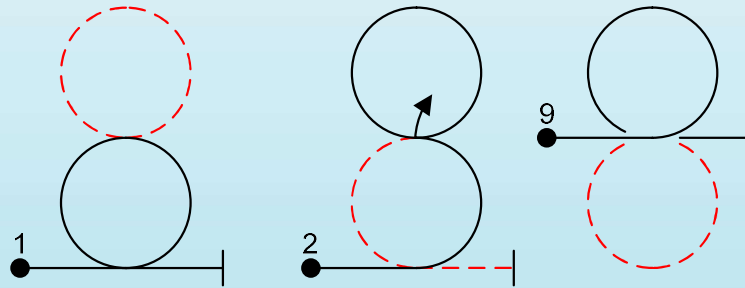

- ❑ Must appear perfectly round and of equal size:
  - 1 point for each radii change
  - 1 point if the two loops are not the same size.
- ❑ Must begin and end at the same altitude.
- ❑ Wind corrected (vertical plane): - $\frac{1}{2}$  point per  $5^\circ$  error.
- ❑ Wings level: -  $\frac{1}{2}$  point per  $5^\circ$ .
- ❑ If half rolls are present, they must immediately follow the loop radius and be flown on a horizontal line. No line may precede or follow the half roll: -2 points for visible line before or after.

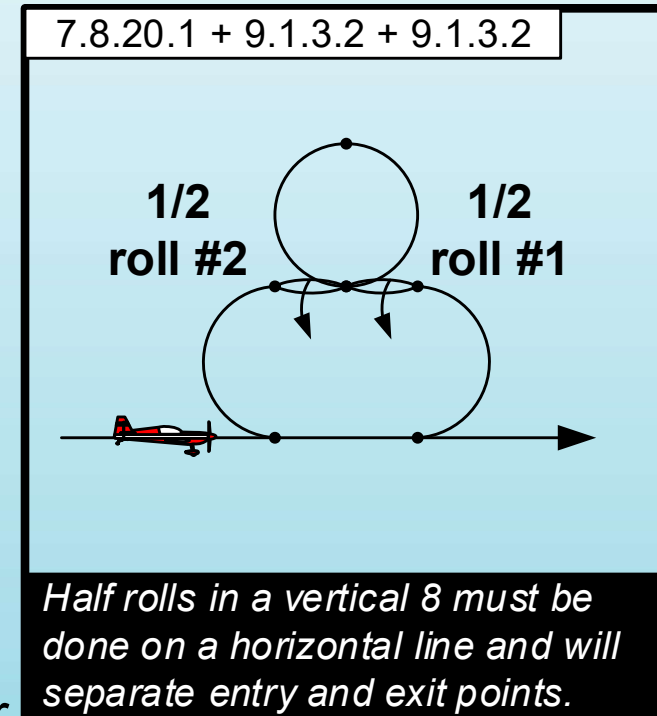

# Judging Criteria



## Family 8 - Combination Lines, Angles, Loops contains:

- Humpty Bumps & Diagonal Humpty Bumps (8.4.1.x - 8.4.28.x)

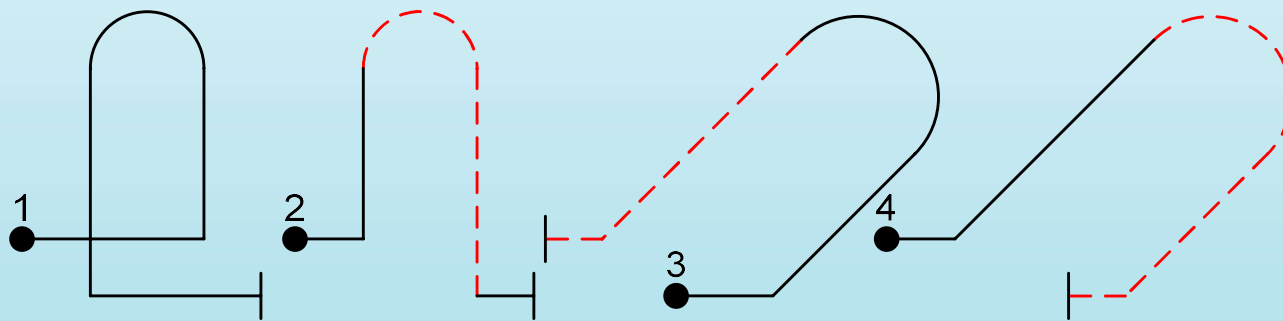

- Half and Reverse Half Cubans (8.5.1.x - 8.5.4.x), (8.5.5.x - 8.5.8.x)

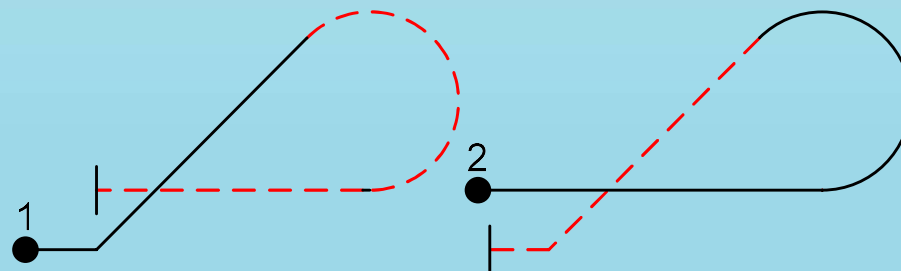

# Judging Criteria



## Family 8 - Combination Lines, Angles, Loops contains:

- Vertical 5/8 loops (8.5.9.x - 8.5.24.x) (Teardrop)

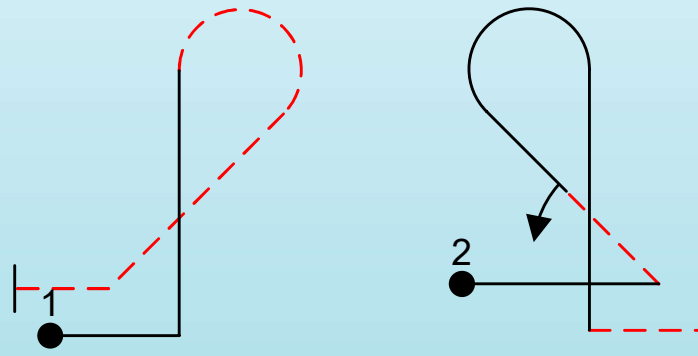

- "P" Loops (8.6.1.x - 8.6.8.x)

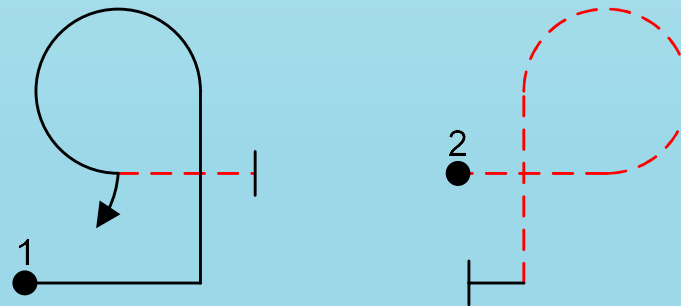



# Judging Criteria



Family 8 - Combination Lines, Angles, Loops contains:

➤ Reversing "P" Loops (8.6.9.x - 8.6.16.x)

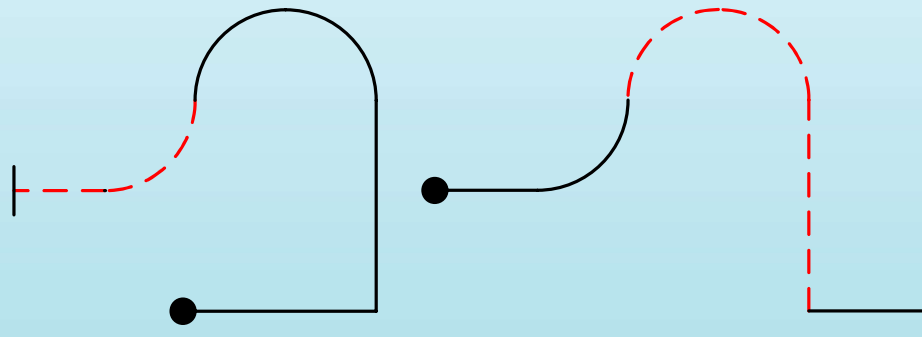

➤ "Q" Loops (8.7.1.x - 8.7.8.x)

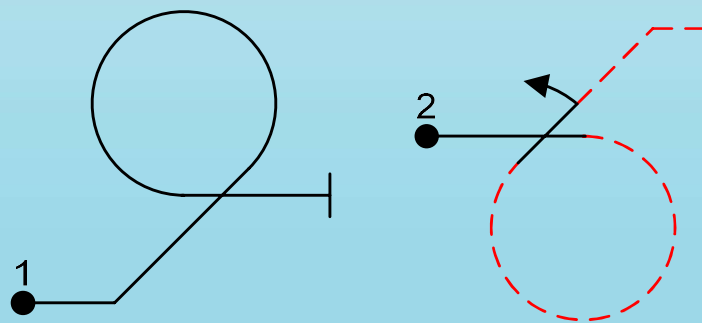

# Judging Criteria



## Family 8 - Combination Lines, Angles, Loops contains:

### ➤ Double Humpty Bumps (8.8.1.x - 8.8.8.x)

Both  $\frac{1}{2}$  loops must be round; may have different radii: Loop rules apply.

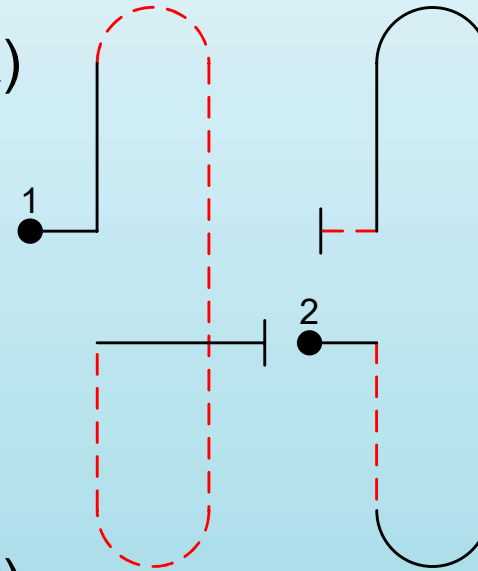

### ➤ Reversing $1\frac{1}{4}$ Loops (8.10.1.x - 8.10.2.x)

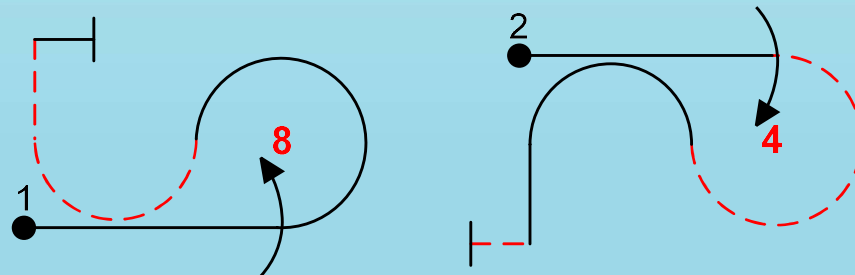

# Judging Criteria



## Family 9 – Rotational Elements

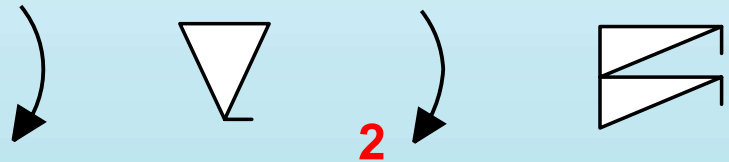

Rotational Elements include aileron rolls, hesitation (point) rolls, snap rolls, and spins.

Rotational elements are elements which are added to base figures drawn from Families 1, 5, 6, 7, and 8 of the Aresti catalog.

# Judging Criteria



## Family 9 - Rotational Elements Rolls and Point Rolls (9.1.1.x-9.8.5.x)

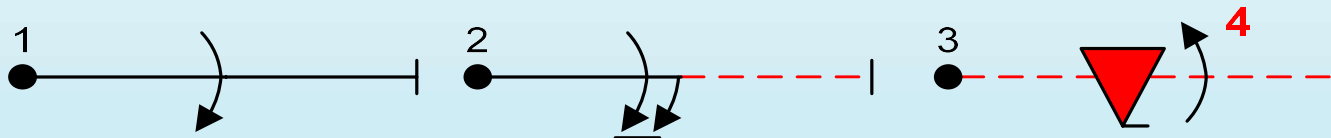

- The rate of roll must be constant: -1 point *per* roll rate change.
- Aircraft must maintain heading and prescribed plane and direction of flight during the roll: - $\frac{1}{2}$  point per  $5^\circ$ .
- Aircraft must stop precisely after stated number of rotations: - $\frac{1}{2}$  point per  $5^\circ$  over or under-rotated.
- Over / under rotation of greater than  $90^\circ$  is a zero.
- Linked rolls must be flown as one continuous figure.
- Unlinked and opposite rolls must have a brief, minimal pause between the rolls. Absence of a perceptible pause between elements of the combination shall be downgraded by 1 point.
- Roll rates may be different in unlinked roll elements without a downgrade.

# Judging Criteria



## Family 9      Rolls and Point Rolls (9.1.1.x-9.8.5.x) continued:

- No stoppages in aileron rolls (9.1.1x – 9.1.5.x) - zero if it can be considered a point roll.
- Point Rolls (hesitation): Roll rates of the rolling segments must be constant; each roll rate segment must match that of the preceding segment. Deviations in roll rate from one segment to the next, or within a segment, are -1 point per occurrence.
- Hesitation on points must be distinct and of equal duration. A visible variation in the duration of the pauses is downgraded by one (1) point. Errors in rotation (under / over rotating the points) are downgraded at a half (.5) point per five (5) degrees. The duration of the roll segments and the pause segments need not be equal.
- If a pause is omitted or imperceptible, the figure is graded a zero (0).

# Judging Criteria



## Family 9 Snap Rolls (9.9 -9.10)

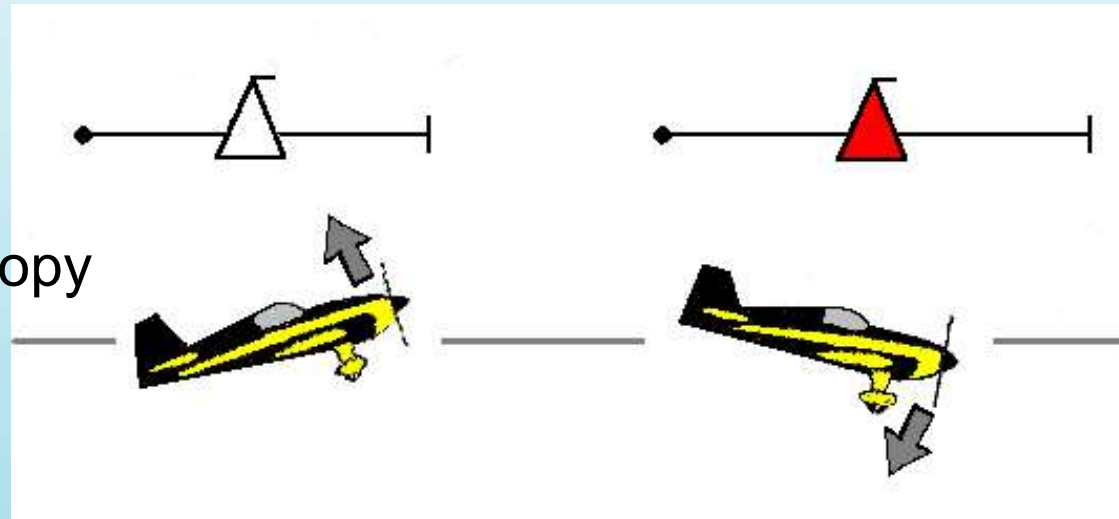

Positive Snap-  
Pitch toward Canopy

Negative Snap-  
Pitch toward Gear

- Nose must depart (pitch) flight path in the correct direction: Zero if either no pitch observed or pitch in wrong direction.
- Autorotation must be initiated: Zero if no autorotation, roll is barreled, or flown as aileron roll.
- Departure and autorotation may occur simultaneously or sequentially (pitch must occur first if sequential).

# Judging Criteria



## Family 9 Snap Rolls (9.9 -9.10)

Positive Snap-  
Pitch toward Canopy

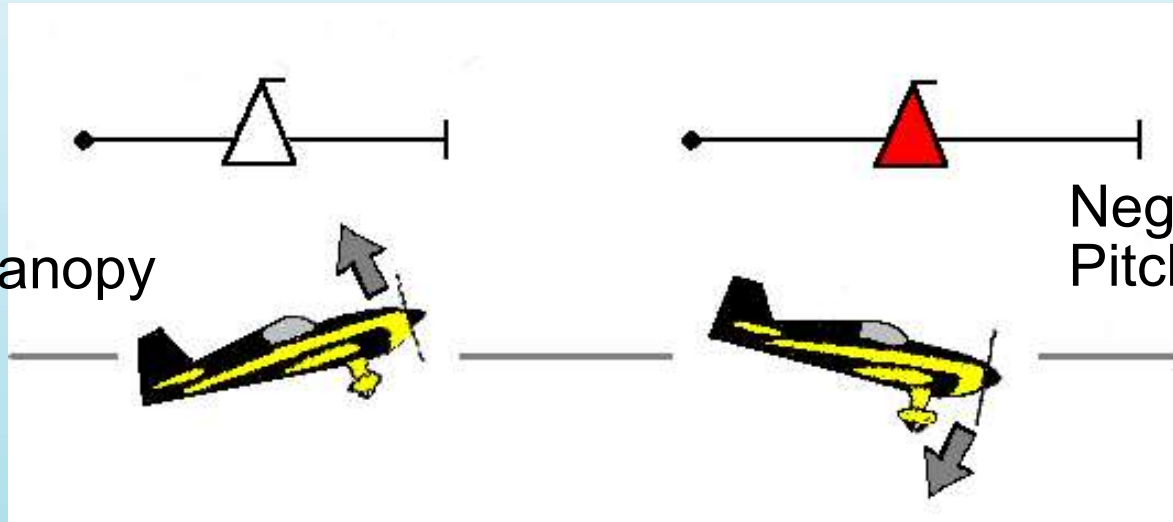

Negative Snap-  
Pitch toward Gear

- ❑ Any rotation or roll observed prior to the required pitch movement is to be downgraded 0.5 points for each 5 degrees of such rotation.
- ❑ Exiting autorotation early and aileronning to the end of the snap is a common error. In these cases, a downgrade of 0.5 point per 5 degrees is applied for the amount of rotation remaining at the point the autorotation ends.

# Judging Criteria



## Family 9 Snap Rolls (9.9 -9.10)

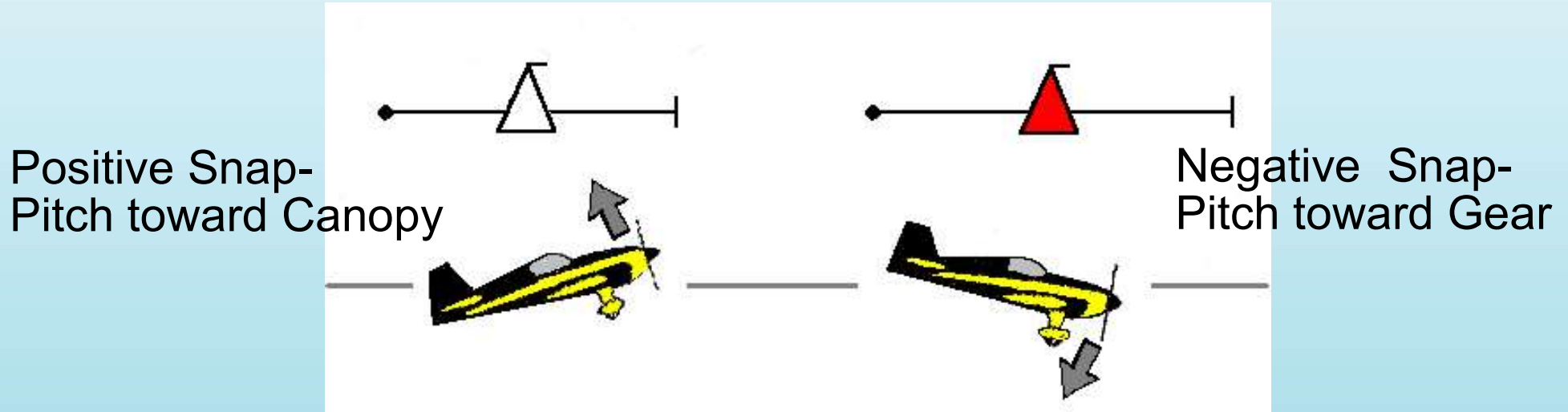

- In the event that the start of autorotation is delayed somewhat after the required pitch movement has been shown, it is possible that the aircraft will draw a visible line between the pitch and the start of autorotation. If this occurs, the maneuver should be zeroed (0).
- No penalty is to be applied for offset, or the realignment of the aircraft immediately after autorotation is completed.



# Judging Criteria

## Family 9 Spins (9.11. - 9.12.)

- ❑ Aircraft must stall from wings level flight: Zero for no stall (roll or snap entry), - 1/2 point per 5° if wings not level on entry.
- ❑ Track and altitude maintained before stall: - 1/2 point per 5° of track or altitude change.
- ❑ The entry line to the spin is judged and downgraded as required in the same manner as any other wind corrected horizontal line.
- ❑ The only exception to judging the entry line is if the spin entry line is also the entry to the sequence (maneuver 1). In this instance, the entry line is not judged, and judging begins at the stall.

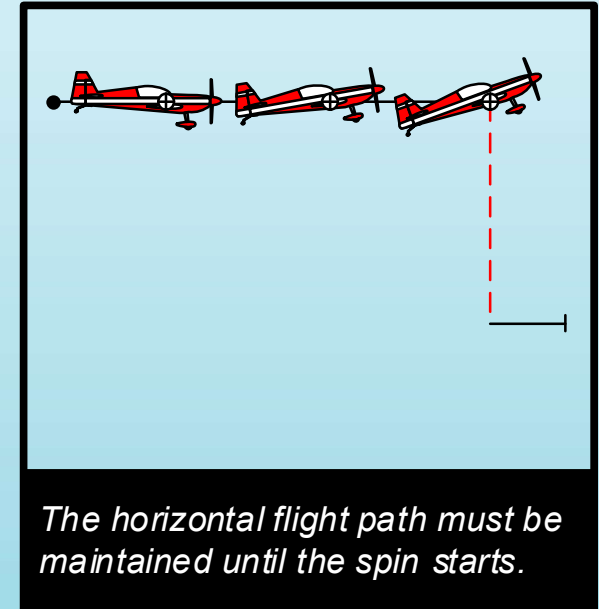
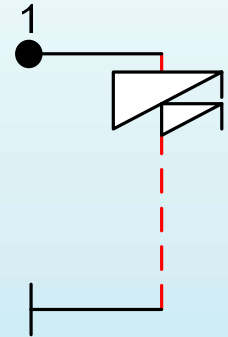

# Judging Criteria



## Family 9 Spins (9.11. - 9.12.)

- ❑ Nose & wing must simultaneously drop in spin direction: -0.5 point per 5° for error.
- ❑ Aircraft *must* auto-rotate during entire spin (no spiral dive).
- ❑ Aircraft *must* establish 90° wind corrected down-line after spin: - 1/2 point per 5° for error from vertical. Omission of this line is to be downgraded one (1) point.

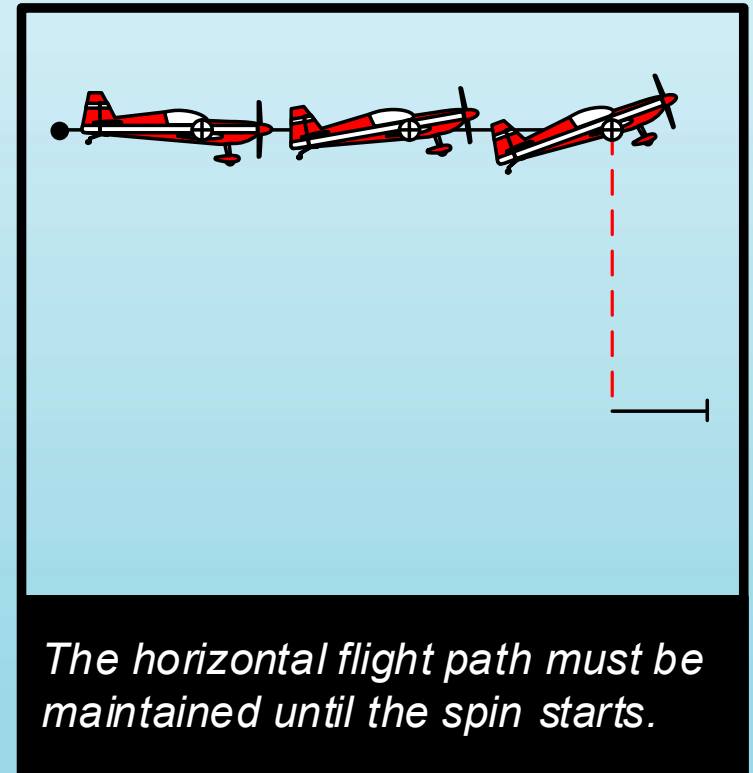



# Freestyle

It's Showtime!

# Freestyle Criteria



## 17.2: Judging the Four (4) Minute Free Program.

- A:** Any number of judges can be utilized; should be a minimum of 3.
- Judges must be familiar with the criteria.
  - Do **not** use randomly selected spectators.
  - A separate individual should be assigned as a timer.
- B:** Criteria is judged from ten (10) to zero (0) in 0.5 increments.
- C:** Judging and timing begins:
- Air-start: When pilot or caller signals the judges.
  - Ground-start: When aircraft's wheels leave the ground.
- Scoring ends when the pilot announces the end of flight, pilot lands, or time reaches 4 minutes.
  - If flight ends prior to 3 minutes 30 seconds, the score will be prorated by a percentage actual flight time using the following formula: Judges Score x (Actual Flight Time/4).
  - If scored flight ends any time after three and one-half minutes, there is no penalty. Judges stop scoring when the timer announces "Time" at the four minute mark.

# Freestyle Criteria



## 17.2: Judging the Four (4) Minute Free Program.

**D:** The following circumstances will disqualify a pilot's flight:

- Any part of the plane touches the ground for any reason other than takeoff or landing.
- The plane crosses onto the pilot side of the Dead Line: a dedicated deadline judge may be used.
- The pilot performs dangerous or high energy maneuvers directed at the judges or spectators as determined by a majority of the judges and/or the CD.
- The pilot touches the plane during flight.

# Freestyle Criteria



## The 4 Minute Freestyle

### **Use of total flight area (20K)**

- The pilot should make full use of the aerobatic airspace.
- Demonstrate a balanced mix of maneuvers at both ends of the flight area - pilots that use only one side, or never leave the middle of the flight area should receive lower scores.
- Pilots should position maneuvers to help judges and spectators observe all aspects of the maneuver.
- Pilots should use a combination of fast, high-energy maneuvers with a small footprint, and long, slow maneuvers using a large footprint to demonstrate a wide range of flight skills.

# Freestyle Criteria



## The 4 Minute Freestyle

### **Originality and Complexity (20K)**

- Pilots should perform a wide variety of figures.
- Pilots who repeatedly perform a single maneuver should receive lower scores, even if that maneuver is highly complex.
- Judges should award the highest scores to pilots that demonstrate a wide variety of complex maneuvers.
- Pilots should demonstrate complexity using all the aerodynamic and gyroscopic forces available, including stalled flight, autorotation, and propeller torque.

# Freestyle Criteria



## The 4 Minute Freestyle

### Precision (20K)

- All maneuvers should be performed with the precision expected of normal maneuvers.
- Roll rates should be constant for continuous rolls.
- Point rolls should have a constant rhythm; should stop at the normal points (e.g., 1/8, 1/4, 1/2, full).
- Lines should be straight, and horizontal, vertical, or 45 degrees.
- Arcs and turns should have constant, continuous radii.
- Altitude changes during a maneuver should be consistent with the maneuver; demonstrate the pilot's ability to control the aircraft at all times.



# Freestyle Criteria



## The 4 Minute Freestyle

### **Artistic impression and Presentation (30K)**

- The music should establish a mood, and the flight of the airplane should match that mood.
- The rhythm of maneuvers should be consistent with that of the music.
- Changes in the music's tempo and or mood should be reflected by similar changes in the flight.
- The aircraft should be in sync with the musical presentation such that it is a collective audio visual artistic performance rather than the aircraft performing with music in the background.

# Freestyle Criteria



## The 4 Minute Freestyle

### Choreography (30K)

- Pilots should demonstrate a well-rehearsed choreography of maneuvers, not a random selection of maneuvers.
- Maneuvers should flow from one maneuver to the next, without long pauses between maneuvers.



# Wrap-Up

Mechanical Zeros  
Judging Unknowns  
Qualities of a Good Judge

# Judging Criteria



## Judging Part-Loop Radii – Quick Reference

Shown below is a range of examples selected from each Aresti family. Note the different treatment for Family 3, and the Family 7.4 Hesitation loops.

- ◆ These corners and looping segments must have a constant and smooth radius, but they do **not** need to match any other radius in the same figure.
- ⊖ These corners and looping segments must have constant and smooth radii that are **identical in size**, or the figure must receive an appropriate downgrade.

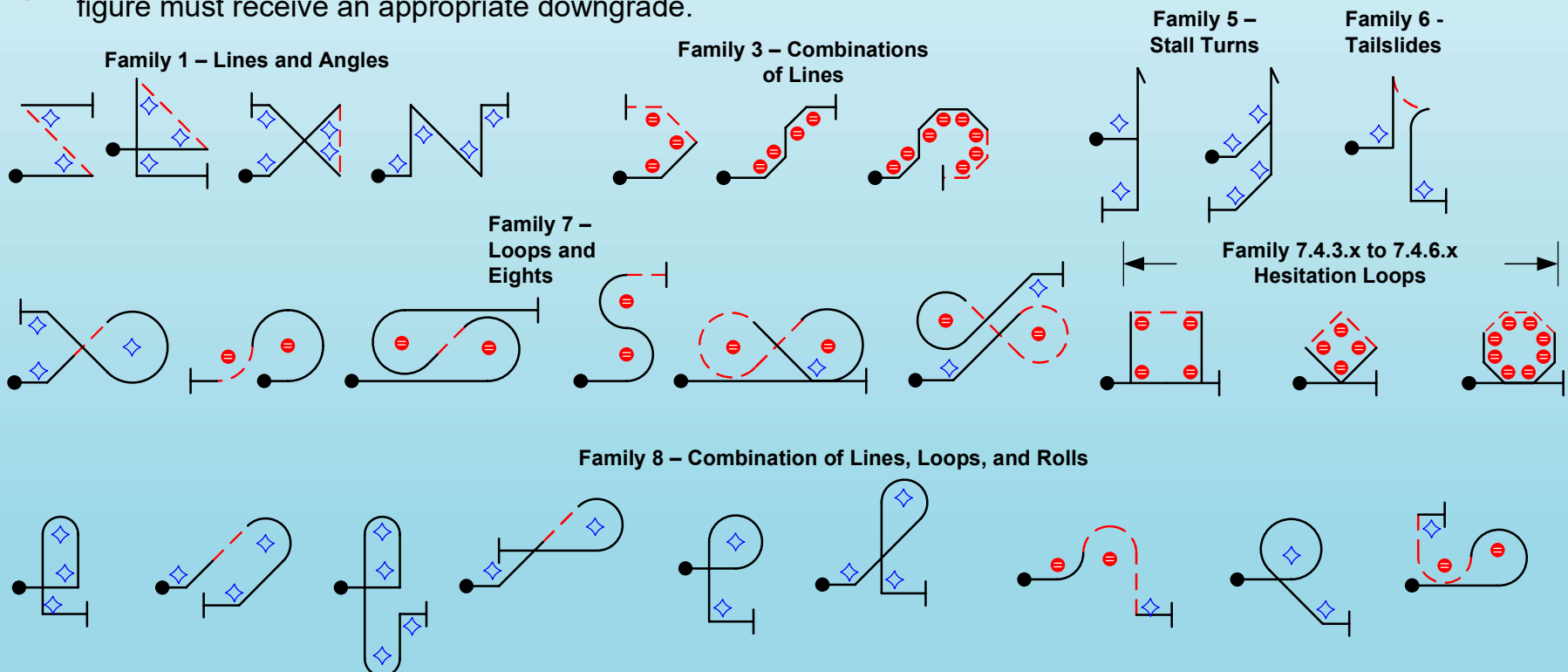

Note: The examples above showed only some of the affected figures. The principle, however, applies to all figures in the catalog with more than one part loop.

# Zeros Review



## Mechanical / Hard Zeros

- Omitting a programmed figure.
- Flying a figure that deviates from the Aresti.
- Adding a figure to the program except when necessary to reposition: Corrective maneuver (Break Penalty is assessed).
- Break in Sequence (Disorientation etc).
- Flying an X-axis figure in wrong direction (Y-axis is non directional).
- Cumulative deviation of roll, pitch or yaw axis greater than 90°.
- Any maneuver flown, even partially, behind the deadline.
- Hammerhead fly over – pivot > 4 wingspans.
- No visible slide on a Tail slide.
- No pitch and or autorotation in snap rolls.
- No stall, or a rolled or snapped entry on spins.

# Judging Unknowns



- Must prepare – review / know the sequence.
- Have a scribe – the seq. is probably unusual to you & you shouldn't look away to write scores.
- If judging Advanced or Unlimited, request an Aresti Caller from the CD – again, avoid looking away from aircraft.
- If not provided, request from the CD a pilot to demonstrate the sequence with a stick plane prior to the round.
- If judging above “your” class, guard against the halo bias.
- Don't judge higher than your current judging capabilities.
- Know the criteria for the Aresti Families.

# Qualities of Judges



## Characteristics of Quality Judging:

**Knowledgeable** – Posses a comprehensive knowledge and understanding of the rules.

**Accountable** – Be able to account for each and every downgrade with it's associated criteria.

**Repeatable** – Consistent application of the rules and criteria is critical.

**Capable** – Physically that is. Have a comfortable chair, stay properly hydrated, be appropriately dressed, proper glasses, etc.

**Equitable** – Be impartial, proper, and unbiased.

**I  
M A  
C A I  
R P L A  
N E S W I T  
H O U T W H E  
E L P A N T S I S  
E Q U A L T O I N D E  
C E N T E X P O S U R E ! ! !**

www.homenmade-gifts-made-easy.com/eye-chart-maker.html



**The End!**

**Thank you, and have a great 2023 contest season!**